

**AGENDA**  
**LONG BRANCH SEWERAGE AUTHORITY**  
**REGULAR MEETING**  
**FEBRUARY 18, 2026**

I. Opening of meeting at \_\_\_\_\_ p.m. by \_\_\_\_\_

II. Notation of attendance and the Pledge of Allegiance

<b>Name</b>	<b>Position</b>	<b>In</b>	<b>Out</b>
Donald S. Riley	Chairman		
Michael Booth	Vice-Chairman		
David Brown	Treasurer		
Bryan Larco	Secretary		
Susie Morris	Asst. Secretary/ Treas.		
Thomas Roguski	Executive Director		
Chuck Fallon	Auditor		
John L. Bonello	Counsel		
John McKelvey	Engineer		
Nicole Woods	Secretary		

III. Announcement by presiding officer, pursuant to New Jersey Open Public Meetings Act, that:

Adequate Notice of this Regular Meeting and of all Regular Meetings for the Year 2025, has been provided by publication thereof in the *Link News* on February 24, 2025 as a “legal” advertisement, in the *Asbury Park Press* on February 26, 2025 as a “legal” advertisement and in the *Coaster* on February 27, 2025 as a “legal” advertisement, and by forwarding duplicates thereof on February 20, 2025, to the Clerks of the City of Long Branch, Borough of West Long Branch and Borough of Monmouth Beach for filing in their respective offices and for posting in a public place in each such Municipality.

IV. Appointment of Board Member – Mr. Donald S. Riley

A. Report by Counsel as to:

1. Appointment by Resolution of Council
2. Filing in Office of Secretary of State
3. Qualification by Oath before City Clerk

B. Welcome by Presiding Officer

V. Organization for the Year Commencing February 1, 2026

A. Motion by \_\_\_\_\_, seconded by \_\_\_\_\_, that Long Branch Sewerage Authority organizes itself for the year commencing February 1, 2026, pursuant to Laws and Statutes of the State of New Jersey in such case made and provided.

Booth	Brown	Riley	Larco	Morris
AYES	NAYS	ABSTAIN	ABSENT	

B. Call by Chairman for Nominations and Elections of Officers for Statutory Term

1. Nominations for Chairman – \_\_\_\_\_

- a. by seconded by
- b. by seconded by

Motion by \_\_\_\_\_, seconded by \_\_\_\_\_ that nominations for Chairman close.

Booth	Brown	Riley	Larco	Morris
AYES	NAYS	ABSTAIN	ABSENT	

2. Nominations for Vice-Chairman – \_\_\_\_\_

- a. by seconded by
- b. by seconded by

Motion by \_\_\_\_\_, seconded by \_\_\_\_\_ that nominations for Vice-Chairman close.

Booth	Brown	Riley	Larco	Morris
AYES	NAYS	ABSTAIN	ABSENT	

3. Nominations for Secretary – \_\_\_\_\_

- a. by seconded by
- b. by seconded by

Motion by \_\_\_\_\_, seconded by \_\_\_\_\_  
that nominations for Secretary close.

Booth	Brown	Riley	Larco	Morris
AYES	NAYS	ABSTAIN	ABSENT	

4. Nominations for Treasurer – \_\_\_\_\_

- a. by seconded by
- b. by seconded by

Motion by \_\_\_\_\_, seconded by \_\_\_\_\_  
that nominations for Treasurer close.

Booth	Brown	Riley	Larco	Morris
AYES	NAYS	ABSTAIN	ABSENT	

5. Nominations for Assistant Secretary-Treasurer – \_\_\_\_\_

- a. by seconded by
- b. by seconded by

Motion by \_\_\_\_\_, seconded by \_\_\_\_\_  
that nominations for Assistant Secretary-Treasurer close.

Booth	Brown	Riley	Larco	Morris
AYES	NAYS	ABSTAIN	ABSENT	

C. Elections

Motion by \_\_\_\_\_, seconded by \_\_\_\_\_  
that elections of Officers for the statutory term commencing February 2026 now  
be held by (open) (closed) ballot.

Booth	Brown	Riley	Larco	Morris
AYES	NAYS	ABSTAIN	ABSENT	

Note 1 – If there is but one nomination for any one or more of the  
offices, the following should be offered

Motion by \_\_\_\_\_, seconded by \_\_\_\_\_  
that the formalities of election be waived, and the nominee(s) declared elected to the Office(s) of the Long Branch Sewerage Authority to which he (they) has (have) been nominated for the statutory term commencing in February.

Booth	Brown	Riley	Larco	Morris
AYES	NAYS	ABSTAIN	ABSENT	

Note 2 - In the event of contest for any office, the Chairman shall appoint a Judge and two Tellers if by closed vote or an Umpire if by open vote.

Note 3 - If there are more than one nomination for Chairman, the Chairman or Acting Chairman shall vacate the Chair after appointing a Member who is not a candidate for the office of Chairman to act as Chairman pro tem. Immediately after the election for Chairman is over, the Chairman pro tem shall step down and the new Chairman assume his duties.

Note 4 - Elections for other Offices shall be held in the same order in which nominations for Office were received.

- D. Appointment, by Chairman, of Budget and Finance Committee  
Comprised of Two Members
- E. Appointment, by Chairman, of Legal and Administrative Committee  
Comprised of Two Members
- F. Appointment, by Chairman, of Engineering Committee  
Comprised of Two Members
- G. Appointment, by Chairman, of Insurance Committee  
Comprised of Two Members
- H. Appointment, by Chairman, of Human Resource Committee  
Comprised of Two Members

### **COMMITTEES FOR YEAR 2026**

- 1. BUDGET & FINANCE  
Chairman – Michael Booth  
Donald Riley
- 2. LEGAL & ADMINISTRATIVE  
Chairman – Bryan Larco  
David Brown

3. ENGINEERING

Chairman – Donald Riley  
David Brown

4. INSURANCE

Chairman – Susie Morris  
Michael Booth

5. HUMAN RESOURCES

Chairman – David Brown  
Michael Booth

I. Designation of Official Internet Website for Public Notices and Legal Notices

Motion by \_\_\_\_\_, seconded by \_\_\_\_\_

Booth	Brown	Riley	Larco	Morris
AYES	NAYS	ABSTAIN	ABSENT	

J. Professional Appointments

LIST OF PROFESSIONALS:

A. Gregory Cannon	Cannon & McGuinn, LLC (General Attorney/Counsel)
B. Charles J. Fallon	Fallon & Company, LLP (Auditor)
C. Jason Capizzi	Law Office of Jason Capizzi, LLC (Bond Attorney/Counsel)
D. David L. Isabel	Trenk, Isabel, Siddiqi & Shahdanian, PC (Environmental Attorney/Counsel)
E. Lester E. Taylor, III	Taylor Law Group, LLC (Labor Attorney/Counsel)
F. Dominic Cinelli	Brown & Brown Metro, LLC (Insurance & Risk Management Consultant)
G. Jordan R. Volk	Colliers Engineering and Design (Consulting Engineer)
H. Scott Thompson	Safenet Solutions, LLC (Information Technologies Consultant)
I. Jordan R. Volk	Colliers Engineering and Design
Leonard A. Faiola	Remington & Vernick Engineers
Keith Chairavallo	CME Associates
Mark Bean	Van Cleef Engineering
Girish Mehta	Prestige Environmental Inc.
Nicholas Rotonda	T & M Associates
William F. Bleiler	Keystone Engineering Group
Eric C. Betz	French & Parello Associates (Special/Capital Project Engineers)

Motion by \_\_\_\_\_, seconded by \_\_\_\_\_

Booth	Brown	Riley	Larco	Morris
AYES	NAYS	ABSTAIN	ABSENT	

**K. Scheduling of Regular Meetings for the Year 2026**

- Wednesday, March 18, 2026 - 3:00 pm
- Wednesday, April 15, 2026 - 5:00 pm
- Wednesday, May 20, 2026 - 3:00 pm
- Wednesday June 17, 2026 - 3:00 pm
- Wednesday, July 15, 2026 - 3:00 pm
- Wednesday, August 19, 2026 - 3:00 pm
- Wednesday, September 16, 2026 - 3:00 pm
- Wednesday, October 21, 2026 - 3:00 pm
- Thursday, November 12, 2026 - 3:00 pm
- Wednesday, December 16, 2026 - 3:00 pm
- Wednesday, January 20, 2027 - 3:00 pm
- Wednesday, February 17, 2027 - 3:00 pm

Donald S. Riley  
Chairman

Motion by \_\_\_\_\_, seconded by \_\_\_\_\_

Booth	Brown	Riley	Larco	Morris
AYES	NAYS	ABSTAIN	ABSENT	

**L. Bank Account Resolution**

Motion by \_\_\_\_\_, seconded by \_\_\_\_\_

Booth	Brown	Riley	Larco	Morris
AYES	NAYS	ABSTAIN	ABSENT	

M. Cash Management Plan

Motion by \_\_\_\_\_, seconded by \_\_\_\_\_

Booth	Brown	Riley	Larco	Morris
AYES	NAYS	ABSTAIN	ABSENT	

VI. Public Participation

Motion by \_\_\_\_\_, seconded by \_\_\_\_\_ that this item of the Agenda be closed.

Booth	Brown	Riley	Larco	Morris
AYES	NAYS	ABSTAIN	ABSENT	

VII. Miscellaneous Suggestions for the Good of Authority

Motion by \_\_\_\_\_, seconded by \_\_\_\_\_ that this item of the Agenda be closed.

Booth	Brown	Riley	Larco	Morris
AYES	NAYS	ABSTAIN	ABSENT	

VIII. As to Minutes of the Regular Meeting of January 21, 2026

Motion by \_\_\_\_\_, seconded by \_\_\_\_\_ that the reading of the minutes of the Regular Meeting of the Long Branch Sewerage Authority held on, January 21, 2026 be dispensed with, and that such Minutes be, and they are hereby, approved as recorded and circulated.

Booth	Brown	Riley	Larco	Morris
AYES	NAYS	ABSTAIN	ABSENT	

IX. As to Minutes of the Executive Session held on January 21, 2026

Motion by \_\_\_\_\_, seconded by \_\_\_\_\_ that the reading of the minutes of the Executive Session held on January 21, 2026, be dispensed with, and that such Minutes be, and they are hereby, approved as recorded and circulated.

Booth	Brown	Riley	Larco	Morris
AYES	NAYS	ABSTAIN	ABSENT	

X. Correspondence

Motion by \_\_\_\_\_, seconded by \_\_\_\_\_, as to items to be received and filed.

Booth	Brown	Riley	Larco	Morris
AYES	NAYS	ABSTAIN	ABSENT	

**LIST OF CORRESPONDENCE FOR REGULAR MEETING**  
**LONG BRANCH SEWERAGE AUTHORITY**  
**FEBRUARY 18, 2026**

1. Certified Notice of Hearing dated 1/12/26 and received 1/20/26 from Applicant Krista & Eric Parker, re: Block 25 Lot 7/ West Long Branch ( NOT LBSA)
2. Affidavit of Publication dated 1/14/26 received 1/21/26 from the Asbury Park Press, re: Official Internet Website for Public Notice and Legal Notices
3. Affidavit of Publication dated 1/22/26 received 1/28/26 from the Asbury Park Press, re: Official Internet Website for Public Notice and Legal Notices
4. Certified Notice of Hearing received 1/29/26 from Carol Zocco, re: 317 Norwood Ave. / Block 105 Lot 17, Applicant is requesting Certificate of Nonconforming use for an existing two-family house.
5. Certified Notice of Hearing received 1/29/26 from Carol Zocco, re: 657 Campbell Ave / Block 166 Lot 1, Applicant is requesting Certificate of Nonconforming use for an existing two-family house.
6. Affidavit of Publication dated 1/25/26 received 1/30/26 from the Asbury Park Press, re: Official Internet Website for Public Notice and Legal Notices.
7. Letter dated 2/2/26 received 2/2/26 from Colliers Engineering & Design, re: 336 Branchport Ave. / Block 357, Lots 2,3,4 & 5.
8. Certified Notice of Hearing dated 1/27/26 received 2/2/26 from Louis E. Granata, Esq., re: 129 Joline Ave / Block 405 Lot 4, subdivision of lot into two (2) lots.
9. Resolution R-13-26 from the City of Long Branch, re: re-appointment for Donald S. Riley to the Board of the Long Branch Sewerage Authority
- ACTION** 10. Letter dated 2/4/26 received 2/4/26 from Colliers Engineering & Design, re: Change Order No. 2 for the Hoey Pump Station Improvements Project
- ACTION** 11. Change of Use application dated 2/4/26 received 2/4/26 from 532 Broadway, LLC, re: 536 Broadway Unit change from three (3) units to two (2) units
12. Certified Notice of Hearing received 2/6/26 from Paul R. Edinger, Esq., re: 54 Dudley Street / Block 258 Lot 14
13. Notice received on 2/9/26 from NJWEA, re: 2026 Winter Technology Transfer Seminar

14. Certified Notice of Hearing dated 2/2/26 received 2/10/26 from Richard C. Sciria, Esq., re: 65 Summers Ave / Block 71 Lots 14.01 & 14.02 / West Long Branch **(NOT LBSA)**
15. Letter dated 2/11/26 received 2/12/26 from Colliers Engineering & Design, re: Engineer's Status Report for February 2026 Meeting
16. Letter dated 2/12/26 received 2/12/26 from Kevin J. Hayes, Sr., re: 119 Lincoln Sq. / Block 11 Lot 1, Letter of Service Availability
17. Affidavit of Publication dated 2/8/26 received 2/13/26 from the Asbury Park Press, re: Official Internet Website for Public Notice and Legal Notices

XI. Report of the Executive Director for the February 2026 Authority Meeting

Motion by \_\_\_\_\_, seconded by \_\_\_\_\_ that the same, as prepared and submitted, is approved, and ordered received and filed and made a part of the Minutes of this Meeting

Booth	Brown	Riley	Larco	Morris
AYES	NAYS	ABSTAIN	ABSENT	

XII. Report by Authority Counsel of the Activities of that Office and of Actions taken since January 21, 2026

Motion by \_\_\_\_\_, seconded by \_\_\_\_\_ that all actions taken, and dispositions made by Authority Counsel, of with regard to each and all of the foregoing items be, and they are in all respects, approved, confirmed and ratified.

Booth	Brown	Riley	Larco	Morris
AYES	NAYS	ABSTAIN	ABSENT	

XIII. Report by Authority Auditor of the Activities of that Office and of Actions taken since January 21, 2026

Motion by \_\_\_\_\_, seconded by \_\_\_\_\_ that all actions taken by Authority Auditor, of and with regard to each and all of the foregoing items be, and they are in all respects, approved, confirmed and ratified.

Booth	Brown	Riley	Larco	Morris
AYES	NAYS	ABSTAIN	ABSENT	

XIV. Report by Authority Consulting Engineer of the Activities of that Office and of Actions taken since January 21, 2026

- A. Engineer's Report on Redevelopment Projects
- B. Capital Improvement Program
- C. General Engineering

See attached Engineer's Status Report, dated February 11, 2026

Motion by \_\_\_\_\_, seconded by \_\_\_\_\_ that all actions taken by Authority Consulting Engineer, of and with regard to each and all of the foregoing items be, and they are in all respects, approved, confirmed and ratified.

Booth	Brown	Riley	Larco	Morris
AYES	NAYS	ABSTAIN	ABSENT	

XV. Transfers, if any

Resolution by \_\_\_\_\_, seconded by \_\_\_\_\_ that the List of Transfers, as submitted, is approved, ordered, received and filed and made a part of the Minutes of this Meeting.

Booth            Brown            Riley            Larco            Morris  
                  AYES            NAYS            ABSTAIN        ABSENT

XVI. As to Bills submitted for payment by Long Branch Sewerage Authority for the February 18, 2026 Meeting

Resolution by \_\_\_\_\_, seconded by \_\_\_\_\_ that the Schedule of Bills for the month of January 2026 prepared and submitted by the Executive Director for approval, is found regular and payment of each and all thereof, be, and it is, hereby, authorized to be made out of funds of Authority as the same are, or may become, available for such purpose.

Booth            Brown            Riley            Larco            Morris  
                  AYES            NAYS            ABSTAIN        ABSENT

XVII. Report, if any, by Investment Committee

Resolution by \_\_\_\_\_, seconded by \_\_\_\_\_ that the Investments be approved and made.

Booth            Brown            Riley            Larco            Morris  
                  AYES            NAYS            ABSTAIN        ABSENT

XVIII. Old Business

XIX. New Business

XX. Adjournment at \_\_\_\_\_ p.m.

Motion by \_\_\_\_\_, seconded by \_\_\_\_\_ that the meeting be adjourned.

Booth            Brown            Riley            Larco            Morris  
                  AYES            NAYS            ABSTAIN        ABSENT

## RESOLUTION

\_\_\_\_\_ offered the following Resolution and moved its adoption; seconded by \_\_\_\_\_

**WHEREAS**, the Long Branch Sewerage Authority, hereinafter "the Authority", is required to post public notices and legal notices in accordance with law, and

**WHEREAS**, the Authority desires to identify an official internet website for the purpose of posting public notices and legal notices in accordance with law; and

**NOW, THEREFORE, BE IT RESOLVED**, by the Long Branch Sewerage Authority, that pursuant to P.L. 2025, c. 72, the complete text of each public notice and legal notice of the LONG BRANCH SEWERAGE AUTHORITY, MONMOUTH COUNTY may be obtained or viewed by the public on our official public notice website: <https://www.lbsa.net/public-notices/> and also may be accessed via a button labeled "Public Notices – Click Here" located on the front of the LONG BRANCH SEWERAGE AUTHORITY'S homepage website: <https://www.lbsa.net/>

**BE IT FURTHER RESOLVED** that the New Jersey Department of State (NJDOS) has been tasked with providing a statewide listing of legal notices pages. The NJDOS has announced that it is currently working to finalize the hyperlink intake process. A "Statewide Legal Notices" button is available on the NJDOS website at: <https://www.nj.gov/state/> The Statewide Legal Notices Listing webpage is located at: <https://www.nj.gov/state/statewide-legal-notices-list.shtml>

### ROLL CALL:

Mr. Riley -  
Mr. Booth -  
Mr. Brown -  
Mr. Larco -  
Mrs. Morris -

Date: February 18, 2026  
R1.2-26

## RESOLUTION

\_\_\_\_\_ offered the following Resolution and moved its adoption; seconded by \_\_\_\_\_

**WHEREAS**, the Long Branch Sewerage Authority, hereinafter "the Authority", has a need to acquire the services of an Attorney for General Attorney/Counsel, and

**WHEREAS**, the Local Public Contracts Law (N.J.S.A. 40A:11 et seq.) requires that the resolution authorizing the appointment without competitive bidding must be publicly advertised, and

**WHEREAS**, the Executive Director has determined and certified in writing that funds are available for this purpose, and

**WHEREAS**, the anticipated term of this contract is one (1) year commencing on February 19, 2026, and concluding on February 17, 2027, and

**WHEREAS**, the Authority has advertised and subsequently received professional bids on February 5, 2026, per N.J.S.A. 19:44A-20.5 et seq. under the "Fair and Open Process" for contract awards, and

**WHEREAS**, Gregory J. Cannon, Esq. / Cannon & McGuinn, LLC, has submitted a proposal dated February 4, 2026, attached hereto and made a part hereof, per the Authority's Request for Proposals for Professional Services for 2026, and

**WHEREAS**, Gregory J. Cannon, Esq. / Cannon & McGuinn, LLC, has completed and submitted all documentation required per the Authority's Request for Proposals for Professional Services for 2026, and

**WHEREAS**, the Authority's Legal & Administrative Committee has recommended the Authority appoint Gregory J. Cannon, Esq. / Cannon & McGuinn, LLC, as General Attorney/Counsel.

**NOW, THEREFORE, BE IT RESOLVED** by Long Branch Sewerage Authority that Gregory J. Cannon, Esq. / Cannon & McGuinn, is appointed as General Attorney/Counsel for the one (1) year term commencing on February 19, 2026, and concluding on February 17, 2027.

**BE IT FURTHER RESOLVED** that the Executive Director and/or Chairman are authorized to enter into a contract with Gregory J. Cannon, Esq. / Cannon & McGuinn, LLC, to effectuate this resolution.

**BE IT FURTHER RESOLVED** that this appointment is being made without competitive bidding because it involves a member of a recognized profession licensed and regulated by Law and is, therefore exempt under N.J.S.A. 40A:11-5 et seq.

**BE IT FURTHER RESOLVED** that this appointment is made after request and receipt of proposals in accordance with N.J.S.A. 19:44A-20.5 et seq. under the “Fair and Open Process” for contract awards.

**BE IT FURTHER RESOLVED** that the Authority shall publish notice of this professional services appointment pursuant to N.J.S.A. 40A:11-5.

ROLL CALL:

Mr. Riley -  
Mr. Booth -  
Mr. Brown -  
Mr. Larco -  
Mrs. Morris -

Date: February 18, 2026  
R2.2-26  
Exhibits A & B

## RESOLUTION

\_\_\_\_\_ offered the following Resolution and moved its adoption; seconded by \_\_\_\_\_

**WHEREAS**, the Long Branch Sewerage Authority, hereinafter "the Authority", has a need to acquire the services of a certified public accountant or a registered municipal accountant for Auditor, and

**WHEREAS**, the Local Public Contracts Law (N.J.S.A. 40A:11 et seq.) requires that the resolution authorizing the appointment without competitive bidding must be publicly advertised, and

**WHEREAS**, the Executive Director has determined and certified in writing that funds are available for this purpose, and

**WHEREAS**, the anticipated term of this contract is one (1) year commencing on February 19, 2026, and concluding on February 17, 2027, and

**WHEREAS**, the Authority has advertised and subsequently received professional bids on February 5, 2026, per N.J.S.A. 19:44A-20.5 et seq. under the "Fair and Open Process" for contract awards, and

**WHEREAS**, Charles J. Fallon / Fallon & Company LLP, has submitted a proposal dated January 19, 2026, attached hereto and made a part hereof, per the Authority's Request for Proposals for Professional Services for 2026, and

**WHEREAS**, Charles J. Fallon / Fallon & Company LLP, has completed and submitted all documentation required per the Authority's Request for Proposals for Professional Services for 2026, and

**WHEREAS**, the Authority's Legal & Administrative Committee has recommended the Authority appoint Charles J. Fallon / Fallon & Company LLP, as Auditor.

**NOW, THEREFORE, BE IT RESOLVED** by Long Branch Sewerage Authority that Charles J. Fallon / Fallon & Company LLP, is appointed as Auditor for the one (1) year term commencing on February 19, 2026, and concluding on February 17, 2027.

**BE IT FURTHER RESOLVED** that the Executive Director and/or Chairman are authorized to enter into a contract with Charles J. Fallon / Fallon & Company LLP, to effectuate this resolution.

**BE IT FURTHER RESOLVED** that this appointment is being made without competitive bidding because it involves a member of a recognized profession licensed and regulated by Law and is, therefore exempt under N.J.S.A. 40A:11-5 et seq.

**BE IT FURTHER RESOLVED** that this appointment is made after request and receipt of proposals in accordance with N.J.S.A. 19:44A-20.5 et seq. under the "Fair and Open Process" for contract awards.

**BE IT FURTHER RESOLVED** that the Authority shall publish notice of this professional services appointment pursuant to N.J.S.A. 40A:11-5.

ROLL CALL:

Mr. Riley -  
Mr. Booth -  
Mr. Brown -  
Mr. Larco -  
Mrs. Morris -

Date: February 18, 2026  
R3.2-25  
Exhibits C & D

## RESOLUTION

\_\_\_\_\_ offered the following Resolution and moved its adoption; seconded by  
\_\_\_\_\_

**WHEREAS**, the Long Branch Sewerage Authority, hereinafter "the Authority", has a need to acquire the services of an Attorney for Bond Attorney/Counsel, and

**WHEREAS**, the Local Public Contracts Law (N.J.S.A. 40A:11 et seq.) requires that the resolution authorizing the appointment without competitive bidding must be publicly advertised, and

**WHEREAS**, the Executive Director has determined and certified in writing that funds are available for this purpose, and

**WHEREAS**, the anticipated term of this contract is one (1) year commencing on February 19, 2026, and concluding on February 17, 2027, and

**WHEREAS**, the Authority has advertised and subsequently received professional bids on February 5, 2026, per N.J.S.A. 19:44A-20.5 et seq. under the "Fair and Open Process" for contract awards, and

**WHEREAS**, Jason P. Capizzi, Esq. / Law Office of Jason P. Capizzi, LLC has submitted a proposal dated February 5, 2026, attached hereto and made a part hereof, per the Authority's Request for Proposals for Professional Services for 2026, and

**WHEREAS**, Jason P. Capizzi, Esq. / Law Office of Jason P. Capizzi, LLC has completed and submitted all documentation required per the Authority's Request for Proposals for Professional Services for 2026, and

**WHEREAS**, the Authority's Legal & Administrative Committee has recommended the Authority appoint Jason P. Capizzi, Esq. / Law Office of Jason P. Capizzi, LLC as Bond Attorney/Counsel.

**NOW, THEREFORE, BE IT RESOLVED** by Long Branch Sewerage Authority that Jason P. Capizzi, Esq. / Law Office of Jason P. Capizzi, is appointed as Bond Attorney/Counsel for the one (1) year term commencing on February 19, 2026, and concluding on February 17, 2027.

**BE IT FURTHER RESOLVED** that the Executive Director and/or Chairman are authorized to enter into a contract with Jason P. Capizzi, Esq. / Law Office of Jason P. Capizzi, LLC to effectuate this resolution.

**BE IT FURTHER RESOLVED** that this appointment is being made without competitive bidding because it involves a member of a recognized profession licensed and regulated by Law and is, therefore exempt under N.J.S.A. 40A:11-5 et seq.

**BE IT FURTHER RESOLVED** that this appointment is made after request and receipt of proposals in accordance with N.J.S.A. 19:44A-20.5 et seq. under the “Fair and Open Process” for contract awards.

**BE IT FURTHER RESOLVED** that the Authority shall publish notice of this professional services appointment pursuant to N.J.S.A. 40A:11-5.

ROLL CALL:

Mr. Riley -  
Mr. Booth -  
Mr. Brown -  
Mr. Larco -  
Mrs. Morris -

Date: February 18, 2026  
R4.2-26  
Exhibits E & F

## RESOLUTION

\_\_\_\_\_ offered the following Resolution and moved its adoption; seconded by \_\_\_\_\_

**WHEREAS**, the Long Branch Sewerage Authority, hereinafter "the Authority", has a need to acquire the services of an Attorney for Environmental Attorney/Counsel, and

**WHEREAS**, the Local Public Contracts Law (N.J.S.A. 40A:11 et seq.) requires that the resolution authorizing the appointment without competitive bidding must be publicly advertised, and

**WHEREAS**, the Executive Director has determined and certified in writing that funds are available for this purpose, and

**WHEREAS**, the anticipated term of this contract is one (1) year commencing on February 19, 2026, and concluding on February 17, 2027, and

**WHEREAS**, the Authority has advertised and subsequently received professional bids on February 5, 2026 per N.J.S.A. 19:44A-20.5 et seq. under the "Fair and Open Process" for contract awards, and

**WHEREAS**, David L. Isabel, Esq. / Trenk, Isabel, Siddiqi & Shahdanian, PC, has submitted a proposal received January 30, 2026, attached hereto and made a part hereof, per the Authority's Request for Proposals for Professional Services for 2026, and

**WHEREAS**, David L. Isabel, Esq. / Trenk, Isabel, Siddiqi & Shahdanian, PC, has completed and submitted all documentation required per the Authority's Request for Proposals for Professional Services for 2026, and

**WHEREAS**, the Authority's Legal & Administrative Committee has recommended the Authority appoint David L. Isabel, Esq. / Trenk, Isabel, Siddiqi & Shahdanian, PC, as Environmental Attorney/Counsel.

**NOW, THEREFORE, BE IT RESOLVED** by Long Branch Sewerage Authority that David L. Isabel, Esq. / Trenk, Isabel, Siddiqi & Shahdanian, PC, is appointed as Environmental Attorney/Counsel for the one (1) year term commencing on February 19, 2026, and concluding on February 17, 2027.

**BE IT FURTHER RESOLVED** that the Executive Director and/or Chairman are authorized to enter into a contract with David L. Isabel, Esq. / Trenk, Isabel, Siddiqi & Shahdanian, PC, to effectuate this resolution.

**BE IT FURTHER RESOLVED** that this appointment is being made without competitive bidding because it involves a member of a recognized profession licensed and regulated by Law and is, therefore exempt under N.J.S.A. 40A:11-5 et seq.

**BE IT FURTHER RESOLVED** that this appointment is made after request and receipt of proposals in accordance with N.J.S.A. 19:44A-20.5 et seq. under the “Fair and Open Process” for contract awards.

**BE IT FURTHER RESOLVED** that the Authority shall publish notice of this professional services appointment pursuant to N.J.S.A. 40A:11-5.

ROLL CALL:

Mr. Riley -  
Mr. Booth -  
Mr. Brown -  
Mr. Larco -  
Mrs. Morris -

Date: February 18, 2026  
R5.2-26  
Exhibits G & H

## RESOLUTION

\_\_\_\_\_ offered the following Resolution and moved its adoption; seconded by \_\_\_\_\_

**WHEREAS**, the Long Branch Sewerage Authority, hereinafter "the Authority", has a need to acquire the services of an Attorney for Labor Attorney/Counsel, and

**WHEREAS**, the Local Public Contracts Law (N.J.S.A. 40A:11 et seq.) requires that the resolution authorizing the appointment without competitive bidding must be publicly advertised, and

**WHEREAS**, the Executive Director has determined and certified in writing that funds are available for this purpose, and

**WHEREAS**, the anticipated term of this contract is one (1) year commencing on February 19, 2026, and concluding on February 17, 2027, and

**WHEREAS**, the Authority has advertised and subsequently received professional bids on February 5, 2026, per N.J.S.A. 19:44A-20.5 et seq. under the "Fair and Open Process" for contract awards, and

**WHEREAS**, Lester E. Taylor, III / Taylor Law Group, LLC, has submitted a proposal received February 4, 2026, attached hereto and made a part hereof, per the Authority's Request for Proposals for Professional Services for 2026, and

**WHEREAS**, Lester E. Taylor, III / Taylor Law Group, LLC, has completed and submitted all documentation required per the Authority's Request for Proposals for Professional Services for 2026, and

**WHEREAS**, the Authority's Legal & Administrative Committee has recommended the Authority appoint Lester E. Taylor, III / Taylor Law Group, LLC, as Labor Attorney/Counsel.

**NOW, THEREFORE, BE IT RESOLVED** by Long Branch Sewerage Authority that Lester E. Taylor, III / Taylor Law Group, LLC, is appointed as Labor Attorney/Counsel for the one (1) year term commencing on February 19, 2026, and concluding on February 17, 2027.

**BE IT FURTHER RESOLVED** that the Executive Director and/or Chairman are authorized to enter into a contract with Lester E. Taylor, III / Taylor Law Group, LLC, to effectuate this resolution.

**BE IT FURTHER RESOLVED** that this appointment is being made without competitive bidding because it involves a member of a recognized profession licensed and regulated by Law and is, therefore exempt under N.J.S.A. 40A:11-5 et seq.

**BE IT FURTHER RESOLVED** that this appointment is made after request and receipt of proposals in accordance with N.J.S.A. 19:44A-20.5 et seq. under the "Fair and Open Process" for contract awards.

**BE IT FURTHER RESOLVED** that the Authority shall publish notice of this professional services appointment pursuant to N.J.S.A. 40A:11-5.

ROLL CALL:

Mr. Riley -  
Mr. Booth -  
Mr. Brown -  
Mr. Larco -  
Mrs. Morris -

Date: February 18, 2026

R6.2-26

Exhibits I & J

## RESOLUTION

\_\_\_\_\_ offered the following Resolution and moved its adoption; seconded by \_\_\_\_\_

**WHEREAS**, the Long Branch Sewerage Authority, hereinafter "the Authority", has a need to acquire the services of a professional for Insurance and Risk Management Consultant, and

**WHEREAS**, the Local Public Contracts Law (N.J.S.A. 40A:11 et seq.) requires that the resolution authorizing the appointment without competitive bidding must be publicly advertised, and

**WHEREAS**, the Executive Director has determined and certified in writing that funds are available for this purpose, and

**WHEREAS**, the anticipated term of this contract is one (1) year commencing on February 19, 2026, and concluding on February 17, 2027, and

**WHEREAS**, the Authority has advertised and subsequently received professional bids on February 5, 2026, per N.J.S.A. 19:44A-20.5 et seq. under the "Fair and Open Process" for contract awards, and

**WHEREAS**, Dominic S. Cinelli / Brown & Brown Metro, LLC, has submitted a proposal received January 28, 2026 attached hereto and made a part hereof, per the Authority's Request for Proposals for Professional Services for 2026, and

**WHEREAS**, Dominic S. Cinelli / Brown & Brown Metro, LLC, has completed and submitted all documentation required per the Authority's Request for Proposals for Professional Services for 2026, and

**WHEREAS**, the Authority's Legal & Administrative Committee has recommended the Authority appoint Dominic S. Cinelli / Brown & Brown Metro, LLC, as Insurance and Risk Management Consultant.

**NOW, THEREFORE, BE IT RESOLVED** by Long Branch Sewerage Authority that Dominic S. Cinelli / Brown & Brown Metro, LLC, is appointed as Insurance and Risk Management Consultant for the one (1) year term commencing on February 19, 2026, and concluding on February 17, 2027.

**BE IT FURTHER RESOLVED** that the Executive Director and/or Chairman are authorized to enter into a contract with Dominic S. Cinelli / Brown & Brown Metro, LLC, to effectuate this resolution.

**BE IT FURTHER RESOLVED** that this appointment is being made without competitive bidding because it involves a member of a recognized profession licensed and regulated by Law and is, therefore exempt under N.J.S.A. 40A:11-5 et seq.

**BE IT FURTHER RESOLVED** that this appointment is made after request and receipt of proposals in accordance with N.J.S.A. 19:44A-20.5 et seq. under the “Fair and Open Process” for contract awards.

**BE IT FURTHER RESOLVED** that the Authority shall publish notice of this professional services appointment pursuant to N.J.S.A. 40A:11-5.

ROLL CALL:

Mr. Riley -  
Mr. Booth -  
Mr. Brown -  
Mr. Larco -  
Mrs. Morris -

Date: February 18, 2026

R7.2-26

Exhibits K & L

## RESOLUTION

\_\_\_\_\_ offered the following Resolution and moved its adoption; seconded by \_\_\_\_\_

**WHEREAS**, the Long Branch Sewerage Authority, hereinafter "the Authority", has a need to acquire the services of a professional engineer for Consulting Engineer, and

**WHEREAS**, the Local Public Contracts Law (N.J.S.A. 40A:11 et seq.) requires that the resolution authorizing the appointment without competitive bidding must be publicly advertised, and

**WHEREAS**, the Executive Director has determined and certified in writing that funds are available for this purpose, and

**WHEREAS**, the anticipated term of this contract is one (1) year commencing on February 19, 2026, and concluding on February 17, 2027, and

**WHEREAS**, the Authority has advertised and subsequently received professional bids on February 5, 2026, per N.J.S.A. 19:44A-20.5 et seq. under the "Fair and Open Process" for contract awards, and

**WHEREAS**, Jordan R. Volk, P.E., P.M.P. / Colliers Engineering and Design, has submitted a proposal dated February 5, 2026, attached hereto and made a part hereof, per the Authority's Request for Proposals for Professional Services for 2026, and

**WHEREAS**, Jordan R. Volk, P.E., P.M.P. / Colliers Engineering and Design, has completed and submitted all documentation required per the Authority's Request for Proposals for Professional Services for 2026, and

**WHEREAS**, the Authority's Legal & Administrative Committee has recommended the Authority appoint Jordan R. Volk, P.E. P.M.P., / Colliers Engineering and Design, as Consulting Engineer.

**NOW, THEREFORE, BE IT RESOLVED** by Long Branch Sewerage Authority that Jordan R. Volk, P.E. P.M.P. / Colliers Engineering and Design, is appointed as Consulting Engineer for the one (1) year term commencing on February 19, 2026, and concluding on February 17, 2027.

**BE IT FURTHER RESOLVED** that the Executive Director and/or Chairman are authorized to enter into a contract with Jordan R. Volk, P.E., P.M.P. / Colliers Engineering and Design, to effectuate this resolution.

**BE IT FURTHER RESOLVED** that this appointment is being made without competitive bidding because it involves a member of a recognized profession licensed and regulated by Law and is, therefore exempt under N.J.S.A. 40A:11-5 et seq.

**BE IT FURTHER RESOLVED** that this appointment is made after request and receipt of proposals in accordance with N.J.S.A. 19:44A-20.5 et seq. under the “Fair and Open Process” for contract awards.

**BE IT FURTHER RESOLVED** that the Authority shall publish notice of this professional services appointment pursuant to N.J.S.A. 40A:11-5.

**ROLL CALL:**

Mr. Riley -  
Mr. Booth -  
Mr. Brown -  
Mr. Larco -  
Mrs. Morris -

Date: February 18, 2026  
R8.2-26  
Exhibits M & N

## RESOLUTION

\_\_\_\_\_ offered the following Resolution and moved its adoption; seconded by \_\_\_\_\_

**WHEREAS**, the Long Branch Sewerage Authority, hereinafter "the Authority", has a need to acquire the services of a professional for Information Technologies (IT) Consultant, and

**WHEREAS**, the Local Public Contracts Law (N.J.S.A. 40A:11 et seq.) requires that the resolution authorizing the appointment without competitive bidding must be publicly advertised, and

**WHEREAS**, the Executive Director has determined and certified in writing that funds are available for this purpose, and

**WHEREAS**, the anticipated term of this contract is one (1) year commencing on February 19, 2026, and concluding on February 17, 2027, and

**WHEREAS**, the Authority has advertised and subsequently received professional bids on February 5, 2026, per N.J.S.A. 19:44A-20.5 et seq. under the "Fair and Open Process" for contract awards, and

**WHEREAS**, Scott Thompson / Safenet Solutions, LLC, has submitted a proposal received January 27, 2026, attached hereto and made a part hereof, per the Authority's Request for Proposals for Professional Services for 2026, and

**WHEREAS**, Scott Thompson / Safenet Solutions, LLC, has completed and submitted all documentation required per the Authority's Request for Proposals for Professional Services for 2026, and

**WHEREAS**, the Authority's Legal & Administrative Committee has recommended the Authority appoint Scott Thompson / Safenet Solutions, LLC, as Information Technologies (IT) Consultant.

**NOW, THEREFORE, BE IT RESOLVED** by Long Branch Sewerage Authority that Scott Thompson / Safenet Solutions, LLC, is appointed as Information Technologies (IT) Consultant for the one (1) year term commencing on February 19, 2026, and concluding on February 17, 2027.

**BE IT FURTHER RESOLVED** that the Executive Director and/or Chairman are authorized to enter into a contract with Scott Thompson / Safenet Solutions, LLC, to effectuate this resolution.

**BE IT FURTHER RESOLVED** that this appointment is being made without competitive bidding because it involves a member of a recognized profession licensed and regulated by Law and is, therefore exempt under N.J.S.A. 40A:11-5 et seq.

**BE IT FURTHER RESOLVED** that this appointment is made after request and receipt of proposals in accordance with N.J.S.A. 19:44A-20.5 et seq. under the “Fair and Open Process” for contract awards.

**BE IT FURTHER RESOLVED** that the Authority shall publish notice of this professional services appointment pursuant to N.J.S.A. 40A:11-5.

ROLL CALL:

Mr. Riley -  
Mr. Booth -  
Mr. Brown -  
Mr. Larco -  
Mrs. Morris -

Date: February 18, 2026  
R9.2-26  
Exhibits O & P

## RESOLUTION

\_\_\_\_\_ offered the following Resolution and moved its adoption; seconded by  
\_\_\_\_\_

**WHEREAS**, the Long Branch Sewerage Authority, hereinafter "the Authority", has a need to acquire the services of professional engineers for Special / Capital Projects Engineers, and

**WHEREAS**, the Local Public Contracts Law (N.J.S.A. 40A:11 et seq.) requires that the resolution authorizing the appointment without competitive bidding must be publicly advertised, and

**WHEREAS**, the Executive Director has determined and certified in writing that funds are available for this purpose, and

**WHEREAS**, the anticipated term of this contract is one (1) year commencing on February 19, 2026, and concluding on February 17, 2027, and

**WHEREAS**, the Authority has advertised and subsequently received professional bids on February 5, 2026, per N.J.S.A. 19:44A-20.5 et seq. under the "Fair and Open Process" for contract awards, and

**WHEREAS**, (1) Jordan R. Volk / Colliers Engineering and Design; (2) Leonard A. Faiola / Remington & Vernick Engineers; (3) Keith Chairavallo / CME Associates; (4) Mark A. Bean / Van Cleef Engineering; (5) Girish Menta / Prestige Environmental, Inc.; (6) Nicholas Rotunda / T and M Associates; (7) Wiliam F. Bleiler / Keystone Engineering Group; and (8) Eric C. Betz / French & Parello Associates have submitted proposals, attached hereto and made a part hereof, per the Authority's Request for Proposals for Professional Services for 2025, and

**WHEREAS**, the above referenced firms have completed and submitted all documentation required per the Authority's Request for Proposals for Professional Services for 2026, and

**WHEREAS**, the Authority's Legal & Administrative Committee has recommended the Authority appoint the above referenced firms as Special / Capital Projects Engineers.

**NOW, THEREFORE, BE IT RESOLVED** by Long Branch Sewerage Authority that (1) Jordan R. Volk / Colliers Engineering and Design; (2) Leonard A. Faiola / Remington & Vernick Engineers; (3) Keith Chairavallo / CME Associates; (4) Mark A. Bean / Van Cleef Engineering; (5) Girish Menta / Prestige Environmental, Inc.; (6) Nicholas Rotunda / T and M Associates; (7) Wiliam F. Bleiler / Keystone Engineering Group; and (8) Eric C. Betz / French & Parello Associates, are appointed as Special / Capital Projects Engineers for the one (1) year term commencing on February 19, 2026, and concluding on February 16, 2027.

**BE IT FURTHER RESOLVED** that the Executive Director and/or Chairman are authorized to enter into a contract with (1) Jordan R. Volk / Colliers Engineering and Design; (2) Leonard A. Faiola / Remington & Vernick Engineers; (3) Keith Chairavallo / CME

Associates; (4) Mark A. Bean / Van Cleef Engineering; (5) Girish Menta / Prestige Environmental, Inc.; (6) Nicholas Rotunda / T and M Associates; (7) Wiliam F. Bleiler / Keystone Engineering Group; and (8) Eric C. Betz / French & Parello Associates to effectuate this resolution.

**BE IT FURTHER RESOLVED** that this appointment is being made without competitive bidding because it involves a member of a recognized profession licensed and regulated by Law and is, therefore exempt under N.J.S.A. 40A:11-5 et seq.

**BE IT FURTHER RESOLVED** that this appointment is made after request and receipt of proposals in accordance with N.J.S.A. 19:44A-20.5 et seq. under the “Fair and Open Process” for contract awards.

**BE IT FURTHER RESOLVED** that the Authority shall publish notice of this professional services appointment pursuant to N.J.S.A. 40A:11-5.

ROLL CALL:

Mr. Riley -  
Mr. Booth -  
Mr. Brown -  
Mr. Larco -  
Mrs. Morris -

Date: February 18, 2026

R10.2-26

Exhibits Q, R, S, T, U, V, W, X & Y

**RESOLUTION**

\_\_\_\_\_ offered the following Resolution and moved its adoption;  
seconded by \_\_\_\_\_

**WHEREAS**, N.J.S.A. 10:4-18 requires public bodies at least once annually to post and distribute a schedule of the regular meetings of the public body for the succeeding year, and

**WHEREAS**, the schedule of regular meetings of the Long Branch Sewerage Authority, including dates, times and locations of meetings, up to and including the Authority 2026 annual reorganization meeting, is attached to the Resolution hereto and made a part hereof.

**NOW, THEREFORE, BE IT RESOLVED BY THE LONG BRANCH SEWERAGE AUTHORITY**, that the said schedule of meetings is approved by the Long Branch Sewerage Authority and said schedule of meetings shall be posted and distributed pursuant to N.J.S.A. 10:4-18.

**ROLL CALL:**

- Mr. Riley -
- Mr. Booth -
- Mr. Brown -
- Mr. Larco -
- Mrs. Morris -

Date: February 18, 2026  
R11.2-26  
Exhibit Z

**RESOLUTION**

\_\_\_\_\_ offered the following Resolution and moved its adoption; seconded by  
\_\_\_\_\_

**BE IT RESOLVED** that the following are hereby designated as depositories of the Long Branch Sewerage Authority and that accounts be opened and maintained in the name of the Long Branch Sewerage Authority as follows:

**KEARNY FEDERAL SAVINGS**

- LBSA - Revolving Fund, Collection Account
- LBSA - Revolving Fund, Payroll Checking Account
- LBSA - Revolving Fund Checking Account
- LBSA – Revolving Fund, EFT Checking Account
- LBSA – Treasurer Fund, Developer’s Escrow

**DESIGANTION OF DEPOSITORIES AND TRUSTEE BANKS**

- Depository Bank: The Bank of New York Mellon
- Depository Bank: Kearny Federal Savings and Its Division
- Depository Bank: Central Jersey Bank
- Depository Bank: New Jersey Cash Management Fund
- Trustee Bank: The Bank of New York Mellon

**ROLL CALL:**

- Mr. Riley -
- Mr. Booth -
- Mr. Brown -
- Mr. Larco -
- Mrs. Morris -

Date: February 18, 2026  
R12.2-26

**RESOLUTION**

\_\_\_\_\_ offered the following Resolution and moved its adoption; seconded  
by \_\_\_\_\_

**WHEREAS**, the Authority desires to adopt a Cash Management Plan pursuant to N.J.S.A. 40A:5-14, attached hereto and made apart hereof.

**NOW, THEREFORE BE IT RESOLVED** by the Long Branch Sewerage Authority that the Authority hereby adopts the attached Cash Management Plan and that the Authority Executive Director is authorized to execute any documents to effectuate the purpose of this Resolution.

ROLL CALL:

Mr. Riley -  
Mr. Booth -  
Mr. Brown -  
Mr. Larco -  
Mrs. Morris -

Date: February 18, 2026  
R13.2-26  
Exhibit AA

## RESOLUTION

\_\_\_\_\_ offered the following Resolution and moved its adoption; seconded by  
\_\_\_\_\_

**WHEREAS**, the Long Branch Sewerage Authority (the "Authority") has undertaken the Hoey Pump Station Improvements Project with Rapid Pump & Meter Service Co., and

**WHEREAS**, the Authority Consulting Engineer, Colliers Engineering & Design, has recommended approval of Change Order No. 2, in their letter dated February 4, 2026, attached hereto and made a part hereof, which increases the project cost by \$22,204.68 from \$1,738,000.00 to \$1,760,204.68 as result of this Change Order.

**NOW, THEREFORE, BE IT RESOLVED** by the Long Branch Sewerage Authority that Change Order No. 2, attached hereto and made a part hereof, is hereby approved.

**BE IT FURTHER RESOLVED** that the Authority Chairman and/or Executive Director are authorized to sign any documents necessary to effectuate this resolution.

### ROLL CALL:

Mr. Riley	-
Mr. Booth	-
Mr. Brown	-
Mr. Larco	-
Mrs. Morris	-

Date: February 18, 2026  
R14.2-26  
Exhibit BB

## RESOLUTION

\_\_\_\_\_ offered the following Resolution and moved its adoption; seconded by \_\_\_\_\_

**WHEREAS**, 532 Broadway, LLC has requested a decrease in the number of units from three (3) to two (2) for service billing in an application to the Executive Director received in February 4, 2026, which is attached hereto to this resolution and made a part hereof, for said property being serviced by the Long Branch Sewerage Authority under Account #4292

**WHEREAS**, the Authority Inspector has made a physical inspection of said property and is of the opinion that the property presently constitutes two (2) units for service billing, and

**NOW, THEREFORE, BE IT RESOLVED** by the Long Branch Sewerage Authority that the number of units for service billing on said property, which is known as 532-538 Broadway is hereby decreased from three (3) units to two (2) units as of the second quarter 2026 and that in the event of a change of use on said property, the Authority reserves its right to assess a connection or reconnection fee.

**BE IT FURTHER RESOLVED** that the Executive Director be authorized to execute any further documents or instruments necessary to effect this Resolution.

**ROLL CALL:**

Mr. Riley                 -  
Mr. Booth                -  
Mr. Brown               -  
Mr. Larco                -  
Mrs. Morris              -

Date: February 18, 2026  
R15.2-26  
Exhibit CC

## RESOLUTION

\_\_\_\_\_ offered the following Resolution and moved its adoption; seconded by  
\_\_\_\_\_

**BE IT RESOLVED BY THE LONG BRANCH SEWERAGE AUTHORITY** that it hereby ratifies and approves the hiring of Bailey Lilienkamp as Operator / Utility Position effective February 19, 2026, or at a starting date thereafter as determined by the Executive Director, at a rate of compensation of \$25.07 per hour. This resolution and employment are conditional upon Bailey Lilienkamp successfully completing a pre-employment physical test, drug test, alcohol test, drivers license (CDL) check, and background check, all to the sole satisfaction of the Long Branch Sewerage Authority. This resolution and employment will become void should Bailey Lilienkamp not successfully complete a pre-employment physical test, drug test, alcohol test, drivers license (CDL) check, and background check, all to the sole satisfaction of the Long Branch Sewerage Authority.

### ROLL CALL:

Mr. Riley -  
Mr. Booth -  
Mr. Brown -  
Mr. Larco -  
Mrs. Morris -

Date: February 18, 2026  
R16.2-26

## RESOLUTION

\_\_\_\_\_ offered the following Resolution and moved its adoption; seconded by  
\_\_\_\_\_

**BE IT RESOLVED BY THE LONG BRANCH SEWERAGE AUTHORITY** that it hereby ratifies and approves the hiring of Kevin McNelis as Operator / Utility Position effective February 19, 2026, or at a starting date thereafter as determined by the Executive Director, at a rate of compensation of \$25.07 per hour. This resolution and employment are conditional upon Kevin McNelis successfully completing a pre-employment physical test, drug test, alcohol test, drivers license (CDL) check, and background check, all to the sole satisfaction of the Long Branch Sewerage Authority. This resolution and employment will become void should Kevin McNelis not successfully complete a pre-employment physical test, drug test, alcohol test, drivers license (CDL) check, and background check, all to the sole satisfaction of the Long Branch Sewerage Authority.

### ROLL CALL:

Mr. Riley -  
Mr. Booth -  
Mr. Brown -  
Mr. Larco -  
Mrs. Morris -

Date: February 18, 2026  
R17.2-26

**RESOLUTION**

\_\_\_\_\_ offered the following resolution and moved its adoption; seconded by \_\_\_\_\_

**WHEREAS**, several of employees have requested permission to attend the New Jersey Water Environmental Association (NJWEA) 2026 Winter Technology Transfer Seminar scheduled for March 9, 2026 to March 12, 2026, and

**WHEREAS**, it is to the benefit of the Long Branch Sewerage Authority to have its employees continue their education and obtain licenses, and

**NOW, THEREFORE, BE IT RESOLVED BY THE LONG BRANCH SEWERAGE AUTHORITY**, that this request to attend the New Jersey Water Environmental Association (NJWEA) 2026 Winter Technology Transfer Seminar is hereby approved subject to the Executive Director’s scheduling and approval of employees, and

**BE IT FURTHER RESOLVED** that the participants follow the rules for "Schooling" covered in the appropriate Article in their Contract.

**ROLL CALL:**

- Mr. Riley -
- Mr. Booth -
- Mr. Brown -
- Mr. Larco -
- Mrs. Morris -

Date: February 18, 2026  
R18.2-26

**RESOLUTION  
RISK MANAGEMENT CONSULTANT**

\_\_\_\_\_ offered the following Resolution and moved its adoption; seconded by  
\_\_\_\_\_

**WHEREAS**, the Long Branch Sewerage Authority (hereinafter referred to as the “Authority”) is a member of the New Jersey Utility Authorities Joint Insurance Fund (hereinafter referred to as the “Fund”), and

**WHEREAS**, the bylaws of said Funds require that each Authority appoint a RISK MANAGEMENT CONSULTANT to perform various professional services as detailed in the bylaws; and

**WHEREAS**, the term of this Agreement shall be one (1) year. However, this agreement may be terminated by either party at any time by mailing to the other written notice, certified mail return receipt, calling for termination at not less than thirty (30) days thereafter; and

**WHEREAS**, the Fund’s bylaws indicate a minimum fee equal to six percent (6%) of the Authority's assessment, which expenditure represents reasonable compensation for the services required and was included in the cost considered by the Authority; and

**WHEREAS**, the judgmental nature of the Risk Management Consultant's duties renders competitive bidding impractical.

**NOW THEREFORE BE IT RESOLVED** that the Long Branch Sewerage Authority does hereby appoint a representative of Dominic Cinelli / Brown & Brown Metro, LLC as its Risk Management Consultant in accordance with the Fund's by laws, and

**BE IT FURTHER** resolved that the Governing Body are hereby authorized and directed to execute the Risk Management Consultant's Agreement annexed hereto and to cause a notice of this decision to be published according to NJSA 40A:11-5 (1) (a) (i).

ROLL CALL:

Mr. Riley -  
Mr. Booth -  
Mr. Brown -  
Mr. Larco -  
Mrs. Morris -

Date: February 18, 2026  
R19.2-26  
Exhibit DD

## RESOLUTION

\_\_\_\_\_ offered the following Resolution and moved its adoption; seconded by \_\_\_\_\_

WHEREAS, Section 8 of the Open Public Meetings Act, Chapter 231, P.L. 1975, permits the exclusion of the public from a meeting in various circumstances, and

WHEREAS, this public body is of the opinion that such circumstances presently exist,

NOW, THEREFORE BE IT RESOLVED by the Long Branch Sewerage Authority as follows:

1. The Public shall be excluded from discussion and action upon the hereinafter subject matters.
2. The general nature of the subject matter to be discussed is as follows:
3. It is anticipated at this time that the above-stated subject matters will be made public when the matters are resolved.
4. This Resolution shall take effect immediately.

### ROLL CALL:

Mr. Riley -  
Mr. Booth -  
Mr. Brown -  
Mr. Larco -  
Mrs. Morris -

Date: February 18, 2026  
ResExSess

**LONG BRANCH SEWERAGE AUTHORITY**  
**EXECUTIVE DIRECTOR'S REPORT**  
**FOR THE PERIOD JANUARY 17, 2026 TO FEBRUARY 17, 2026**

We have treated an average daily flow of 2.15 MGD, the effluent quality being of a good degree with an average suspended solid discharge of 11.9 ppm and an average B.O.D. discharge of 12.8 ppm. We have met all limits of our discharge permit.

The Authority received Request for Proposals for Professional Services on February 5, 2026. The Legal & Administrative Committee reviewed the proposals and made recommendations to the Board regarding professional appointments.

The Authority has determined that two Operator/Utility Crew Position hires are needed. The Authority's management team has interviewed qualified candidates who would be beneficial to the Authority and its operations. The Authority's Human Resources Committee recommended the candidates be hired.

The New Jersey Water Environment Association (NJWEA) 2026 Winter Technology Transfer Seminar is scheduled for March 9 through 12, 2026. Registration is open to all Board Members and Authority Staff wishing to attend. Several Authority Staff have expressed a desire to attend to update their TCH's required to hold their licenses, and it is recommended that the Board approve attendance at this seminar.

The New Jersey Utility Authorities Joint Insurance Fund requires the Authority to appoint a Risk Management Consultant. Brown & Brown has previously performed as the Authority's Risk Management Consultant, and it is recommended that the Board consider reappointing same for the following year.

We have calculated daily and projected flows for the Capacity Assurance Program. Our average twelve-month flow is 2.368 MGD, with an additional 0.36743 MGD in approved and conceptual projects for a total of 2.735 MGD. This gives the Authority an additional available capacity of 2,665,072 gallons per day or 8,884 units based on 300 gallons per day per unit at full capacity, or 7,984 units based on 300 gallons per day per unit at 95% capacity.

The Authority's Collection System Crew for the month has investigated eighteen (18) stoppages, of which eight (8) were the responsibility of the LBSA and ten (10) were the private owners' responsibility.

Respectfully submitted,



Thomas Roguski, PE, CME  
Executive Director

Capacity	Assurance							
	Present Flow	Approved Project	Est. Flow	Conceptual Project	Est. Flow			
	MGD							
		Aqua-Vista (20 + Retail)	0.00436	145 Brighton Avenue (12 + 0.9K)	0.00279			
Jan-26	2.15	394 & 400 Morris Avenue (8)	0.0024	700 Joline Avenue	0.007			
Dec-25	2.19	201 - 215 Third Avenue (30 + 8.2K)	0.00982	479 Ocean Boulevard (3)	0.0009			
Nov-25	2.11	671 Broadway	0.00066	175 Chelsea Avenue (33)	0.0099			
Oct-25	2.18	Reformed Church of LB Housing	0.00338	294 Branchport Avenue (14 + .885K)	0.0042885			
Sep-25	2.29	Monmouth University – BSACAM	0.00265	Synagogue Add. - 295 Park Ave.	0.00521			
Aug-25	2.54	Takanassee Lake (13)	0.00390	Bluffs (109)	0.0327			
Jul-25	2.86	665 Second Avenue (22 + Mix Use)	0.00829	Onada Surf Club Residential (47)	0.01300			
Jun-25	2.53	112 Brighton Avenue (4 + 2K)	0.001401	369-375 Broadway (20 +1K)	0.0061			
May-25	2.37	279 Third Avenue (154B + 11.1K)	0.01651	456 Atlantic Avenue (4)	0.0012			
Apr-25	2.67	169 Chelsea Avenue (4)	0.0012	394 Bath Avenue	0.00120			
Mar-25	2.34	Ocean Acre 119-129 Franklin (8)	0.00240	29 Long Branch Avenue (Calc)	0.018			
Feb-25	2.18	180 Brighton (24 + 5.5K)	0.00595	410 Broadway (94)	0.0282			
12-Month Tot.	28.41	180 Morris Avenue (28 + Office)	0.00457	19 7th Avenue (20 + 1.5K)	0.00405			
		336 Branchport (40 + 4K)	0.0148	115-127 Brighton Avenue (24 + 5K)	0.00770			
Design	5.4	Lower Broadway (299 + 25K)	0.05850	336 Ocean Boulevard (4)	0.00120			
12-Month Avg.	2.368	390-392 Ocean (132)	0.0396	192 Broadway (6 + 1.3K)	0.00193			
Approved	0.2101	156-164 Franklin Avenue (9)	0.00270	648 Second Avenue	0.005			
Conceptual	0.1573	333-345 Second Ave. (14)	0.0042	85 Chelsea Avenue (10)	0.003			
Total	2.735	215 Brighton Avenue (6)	0.0018	163 Washington Comm. Bldg (Calc)	0.000281			
		83 North Broadway (12 + 1.5K)	0.002625	101 Third Ave Wellness Cntr (Calc)	0.002145			
		305 Broadway (Mixed Use)	0.018425	1198 Lincoln Square (5)	0.0015			
		Total Approved Project	0.21013	Total Conceptual Project	0.15730			
				Approved & Conceptual	0.36743			
		95% of capacity is	5.13	Percent of 100% capacity available	49%	2.67	MGD	
				Percent of 95% capacity available	47%	2.40	MGD	
<b>Available in MGD</b>	<b>2.665072</b>			<b>Equivalent Units Available based on 300 gals/day/ unit</b>	<b>8,884 @ 100% Capacity</b>			
				<b>Equivalent Units Available based on 300 gals/day/ unit</b>	<b>7,984 @ 95% Capacity</b>			

101 Crawfords Corner Road  
Suite 3400  
Holmdel New Jersey 07733  
Main: 877 627 3772



February 11, 2025

**VIA EMAIL**

Thomas Roguski, P.E., CME, Executive Director  
Long Branch Sewerage Authority  
150 Joline Avenue  
P.O. Box 720  
Long Branch, New Jersey 07740

Engineer's Status Report  
February 2026 Meeting  
Colliers Engineering & Design Project No. LBS-001

Dear Mr. Roguski,

The following is a report on the status of projects for which Colliers Engineering & Design, Inc. (CED) is responsible:

**1. Capital Projects**

**a. WWTP Expansion Study (LBS-0329)**

Report reviewed at the January 2025 board meeting. Meeting to be scheduled by LBSA with the Engineering Committee to discuss further.

**b. Hoey Pump Station Improvements (LBS-0330)**

Submittal review and coordination with the contractor is ongoing. Contractor anticipates the majority of the upgrade work to start in early spring 2026. The NJDEP conducted their first interim inspection on October 24, 2025. No issues or concerns were raised by the DEP during their inspection. As discussed at previous meetings, CED has been reviewing a proposed change to the size of the elevated platform due to final sizes and spacing of electrical equipment to be installed on the platform. In addition to the platform change, in working with the contractor on the removable access panels for lifting the pumps, it was determined some further modifications to the removable structural grating above the pumps were required to provide the Authority with easy, safe pump access without the need to remove entire grating sections. CED has prepared a change order for review and approval by the Authority and the DEP that covers the above changes. Note that the change order also includes a credit for a change in material to fabricated steel for the pump suction elbows.

## 2. Active Escrow Projects

### a. 180 Morris Avenue (in construction) (LBS-289)

All construction work is complete and final testing and inspections have been performed. Project closeout contingent on completion of completion of punchlist items and submission of outstanding administrative items.

### b. Takanassee (in construction) (LBS-290)

The sanitary main and laterals have been installed. Final testing is complete. Updated punch list was sent to Applicant on October 23, 2024. Developer working on building construction.

### c. Proposed 7-Eleven (LBS-292)

Approval letter was sent to the Applicant on January 7, 2021.

### d. Beachfront LLC (in construction) (LBS-294)

One lateral has been installed and awaits final inspection. Three remaining laterals to be installed at a future date.

### e. Broadway Place (Phase I/II) (in construction) (LBS-295)

The majority of sanitary sewer installation construction work within Broadway is complete and pending final inspection, testing and preparation of a punchlist. The revised plans submitted by the applicant has been reviewed and approved, construction of the sanitary sewer lateral is ongoing.

### f. NJDOT Bridge over Troutman's Creek (LBS-315)

A meeting with NJDOT took place on Friday, June 10, 2022. Follow up meetings with the NJDOT consulting engineer have been held on April 30, 2025 and on June 4, 2025 to discuss recently submitted updated NJDOT utility plans and specifications. Revised documents have been submitted, reviewed and deemed acceptable. The final documents were forwarded to the Authority for endorsement and subsequently forwarded to NJDOT. The Authority will be notified in advance of any of the proposed construction activities that will impact sewer facilities. Additional escrow has been requested from the NJDOT to cover engineering services during construction. The project is currently out to bid, Contractor's have submitted questions regarding bypass requirements of lining work. The Authority and CED have provided input and clarification for the bidders.

**g. Ocean Gate (in construction) (LBS-0316)**

All construction work is complete and final testing and inspections have been performed. All construction related punchlist items have been satisfactorily addressed. Project closeout contingent on submission of outstanding administrative items. The applicant is currently preparing revised as-builts for review and approval.

**h. 175 Chelsea Avenue (LBS-0317)**

A review letter was sent on June 8, 2021 to the Applicant. A revised submission was made, and a letter was sent to the Applicant on September 9, 2021, outlining remaining items to be submitted.

**i. 290 Ocean Avenue (LBS-0321)**

A review letter was sent on January 10, 2022 to the Applicant.

**j. 279 Third Avenue (LBS-0326)**

A review letter was sent to the Applicant on October 3, 2022.

**k. The Atlantic Club (in construction) (LBS-0334)**

Preconstruction meeting was held. Construction start date pending submission, review and approval of administrative items. National Water Main has completed CCTV inspection of the existing main to be lined along S. Bath Avenue. Coordination for the completion of lining work and sanitary sewer work is ongoing.

**l. Santos Subdivision (LBS-0004)**

The applicant has submitted revised plans proposing individual grinder pumps for approval, the NJDEP has confirmed that a TWA will be required for the application. The applicant has satisfactorily addressed all comments and the Authority has endorsed the TWA application.

**m. 156-164 Franklin Avenue (in construction) (LBS-0005)**

Construction of sewer facilities and final testing are complete. Final inspection to be scheduled and punchlist to be issued upon completion of inspection. Developer is constructing buildings in phases. The applicant has requested COs for Lots 5.02, 5.03 and 5.04, inspections for the same have been completed.

**n. Second Avenue Multi-Use Development (in construction) (LBS-0336)**

All closeout documentation has been received, and the application has been closed out. Application to be removed from the active applications list in the following Engineer's Status Report.

**o. 169 Chelsea Avenue (in construction) (LBS-0338)**

Revised plans to eliminate proposed deep connections to existing sewer have been reviewed and approved. The contractor has installed three (3) sanitary sewer laterals of 3 to be constructed and connected to an existing manhole per the approved plans.

**p. 333-345 Second Avenue Proposed Townhouse Development (in construction) (LBS-0339)**

All construction work is complete and final testing and inspections have been performed. All construction related punchlist items have been satisfactorily addressed. Project closeout contingent on submission of outstanding administrative items.

**q. Ocean Acre (in construction) (LBS-0340)**

Preconstruction meeting was held September 12, 2025. Construction start date pending submission, review and approval of administrative items.

**r. Branchport Crossing (LBS-0342)**

Conditional approval letter was provided to the Applicant on February 21, 2025. TWA approval has been received.

**s. Monmouth University BSACAM (in construction) (LBS-0344)**

Sanitary sewer construction is complete and final testing remains to be completed. Final inspection to be scheduled and punchlist to be issued upon completion of inspection.

**t. Sephardic Torah Temple (LBS-0345)**

The application received conditional approval at the October 2024 meeting. Notice has been sent to the Applicant. Resubmission documents have been reviewed and comments provided. Coordinating with the applicant's engineer for completion of a capacity analysis. Cleaning and CCTV of downstream sanitary sewer has been conducted for the purpose of completing the capacity analysis.

**u. RCHP Affordable Housing Corporations (LBS-0346)**

The application received conditional approval at the October 2024 meeting. Notice has been sent to the Applicant. Awaiting submission of revised documents for review and approval.

**v. 201, 213 & 215 Third Ave. (LBS-0347)**

Revised documents have been submitted and reviewed. Review comments were provided November 25, 2025.

**w. Seventh Avenue Apartments (LBS-0349)**

Revised documents have been submitted and reviewed, notice of approval has been sent to the Applicant.

**x. 112 Brighton Avenue (in construction) (LBS-0350)**

Sanitary sewer construction is complete and final testing remains to be completed. Final inspection to be scheduled and punchlist to be issued upon completion of inspection.

**y. 85 Chelsea Avenue (LBS-0351)**

Revised documents have been submitted and reviewed. Review comments were provided December 19, 2025.

**z. 305 Broadway Mixed-Use Development (LBS-0353)**

The application received conditional approval at the August 2025 meeting. Notice has been sent to the Applicant. A capacity study has been completed and the applicant has satisfactorily addressed all comments and the Authority has endorsed the TWA application.

**aa. Wave Condominium (LBS-0354)**

The application received conditional approval at the August 2025 meeting. Notice has been sent to the Applicant. Awaiting submission of revised documents for review and approval.

**bb. 400 Morris Avenue (LBS-0355)**

Revised documents have been submitted and reviewed. Review comments were provided November 14, 2025. Revised documents have been received and are currently under review.

**cc. 648 Second Avenue (LBS-0356)**

The application received conditional approval at the September 2025 meeting. Notice has been sent to the Applicant. Awaiting submission of revised documents for review and approval.

**dd. 83 North Broadway Proposed Mixed-Use Development (LBS-0357)**

Revised documents have been submitted and reviewed. Review comments were provided December 19, 2025.

**ee. 119-127 Brighton Avenue (LBS-0358)**

The application received conditional approval at the November 2025 meeting. Notice has been sent to the Applicant. Revised documents have been received and are currently under review.

Should you have any questions or require any additional information, please do not hesitate to contact me directly.

Sincerely,

Colliers Engineering & Design, Inc.  
(DBA Maser Consulting)



John J. McKelvey, P.E.  
Senior Project Manager

**LONG BRANCH SEWERAGE AUTHORITY  
 RECEIPTS FOR THE MONTH OF JANUARY 2026  
 AMOUNTED TO \$671,272.44**

**DIVIDED AS FOLLOWS:**

		<b>Acct. #</b>
Service, Fees & Interest on Sewer Charges	\$ 637,031.59	300024645
Interest on EFT Account	47.35	300005872
Interest on Revolving Account	52.58	300004652
Interest on Collection Account	741.91	300024645
Interest on Payroll Account	56.55	300024660
Interest on Developers Escrow	595.75	300032044
<b>December 2025 Interest</b>		
Interest on Revenue Fund	20,054.18	217800
Interest on General Fund	12,527.68	217801
Interest on Bond Service Fund	0.30	217802
Interest on Maintenance Reserve Fund	164.55	217803
	<u>\$ 671,272.44</u>	

**Investments as of 2/18/2026**

**C/D's**

Maintenance Reserve Fund - Kearny Bank	\$ 123,000.00
General Fund - Kearny Bank	\$ 140,000.00

**Cash Transfers for the Month of January 2026**

From Operating to Payroll Checking	\$ 162,363.62
From Collection to Payroll Checking	45,613.66
From Developer's Escrow to Collection	0.00
From Collection to Operating Ckg.	983,003.09
From Collection to EFT Checking	76,758.11

**LONG BRANCH SEWERAGE AUTHORITY  
 BANK BALANCE, PETTY CASH, AND INVESTMENTS  
 FOR THE MONTH OF JANUARY 2025  
 AMOUNTED TO \$13,453,314.70**

<b><u>REVOLVING CKG ACCTS.- KEARNEY FEDERAL SVGS.</u></b>		<b><u>Acct. #</u></b>
Payroll Checking	\$ 95,011.31	300024660
Accounts Payable Checking	52.58	300024652
EFT Checking	76,820.88	340785872
Petty Cash	400.00	N/A
	<u>\$ 172,284.77</u>	

<b><u>ESCROW ACCT. - KEARNEY FEDERAL SVGS.</u></b>		<b><u>Acct. #</u></b>
Developer's Escrow	\$ <u>731,003.40</u>	300032044

<b><u>TRUST ACCT. - KEARNEY FEDERAL SVGS.</u></b>		<b><u>Acct. #</u></b>
Collection Account	\$ <u>632,914.64</u>	300024645

<b><u>TRUST ACCOUNTS - BANK OF NEW YORK</u></b>		<b><u>Acct. #</u></b>
<b><u>December 2025 Balances</u></b>		
LBSA Series 2024 Escrow Fund	0.00	958452
Revenue Fund	7,298,688.03	217800
General Fund	4,559,409.33	217801
Bond Service Fund	135.33	217802
Maint. Reserve Fund	58,879.20	217803
	<u>\$ 11,917,111.89</u>	

**Cash Requirements for Payroll**

Payperiod End 1/17/2026 in the amount of	\$ 66,919.27
Payperiod End 1/31/2026 in the amount of	71,168.44

BILL LIST

Range of Checking Accts: First to Last Range of Check Dates: 01/22/26 to 02/17/26  
Report Type: All Checks Report Format: Detail Check Type: Computer: Y Manual: Y Dir Deposit: Y

Check #	Check Date	Vendor	Amount Paid	Charge Account	Account Type	Reconciled/Void	Ref Num
PO #	Item	Description				Contract	Ref Seq Acct
DEV ESCROW		DEVELOPER'S ESCROW					
4395	01/23/26	665SE005 665 SECOND AVE LB, LLC					2205
26000077	1	RETURN OF PERFORMANCE BOND	8,763.06	LBS0336 MB 665 SECOND AVE	Project		1 1
4396	01/28/26	COLLI005 COLLIERS ENGINEERING & DESIGN					2206
26000084	1	ENGINEERING COSTS, LBS0334	1,439.90	LBS-334 THE ATLANTIC CLUB	Project		1 1
4397	01/28/26	COLLI005 COLLIERS ENGINEERING & DESIGN					2206
26000085	1	ENGINEERING COSTS - LBS0336	1,497.50	LBS0336 665 SECOND AVE	Project		2 1
4398	01/30/26	CITY0010 CITY OF LONG BRANCH					2207
26000086	1	ROAD OPENING PERMIT/100-38.01	525.00	100-38-01 650 WOODGATE AVE	Project		1 1
4399	02/09/26	COLLI005 COLLIERS ENGINEERING & DESIGN					2208
26000092	1	REVIEW	490.00	LBS-357 83 NORTH BROADWAY	Project		1 1
4400	02/09/26	COLLI005 COLLIERS ENGINEERING & DESIGN					2209
26000096	1	APPLICATION REVIEW	490.00	LBS0353 305 BROADWAY	Project		1 1
4401	02/09/26	COLLI005 COLLIERS ENGINEERING & DESIGN					2210
26000097	1	APPLICATION REVIEW	142.50	LBS0350 112 BRIGHTON AVE	Project		1 1
4402	02/09/26	Alignment Check				VOID	
4403	02/09/26	COLLI005 COLLIERS ENGINEERING & DESIGN					2211
26000098	1	ENGINEERING REVIEW	160.00	LBS0345 213 LENOX AVENUE	Project		1 1
4404	02/09/26	COLLI005 COLLIERS ENGINEERING & DESIGN					2212
26000099	1	CONSTRUCTION/ OBSERVATION	800.00	LBS0336 665 SECOND AVE	Project		1 1
4405	02/09/26	COLLI005 COLLIERS ENGINEERING & DESIGN					2213
26000100	1	CONSTRUCTION SERVICE	615.00	LBS-334 THE ATLANTIC CLUB	Project		1 1
4406	02/09/26	COLLI005 COLLIERS ENGINEERING & DESIGN					2214
26000101	1	CONSTRUCTION/ADMINISTRATOR	237.50	LBS-295 LOWER BROADWAY	Project		1 1
4407	02/10/26	COLLI005 COLLIERS ENGINEERING & DESIGN					2215
26000103	1	CONSTRUCTION OBSERVATION	6,030.00	LBS-0339 335-345 SECOND AVE	Project		1 1

Check #	Check Date	Vendor	Amount Paid	Charge Account	Account Type	Reconciled/Void Contract	Ref Num	Ref Seq	Num Acct
PO #	Item	Description							
DEV ESCROW DEVELOPER'S ESCROW Continued									
Checking Account Totals			<u>Paid</u>	<u>Void</u>	<u>Amount Paid</u>		<u>Amount</u>	<u>Void</u>	
		Checks:	12	1	21,190.46			0.00	
		Direct Deposit:	0	0	0.00			0.00	
		Total:	12	1	21,190.46			0.00	
EFT CHECKING EFT ACCOUNT									
269	02/17/26					02/17/26	VOID		0
270	02/17/26	Alignment Check					VOID		
271	02/17/26	FRANK005 FRANK BLAISDELL			(Void Reason: INCORRECT ACCT)	02/17/26	VOID		2216
26000057	1	SEMI ANNUAL MEDICARE REIMBURSE	1,110.00		01-900-001-8104		Expenditure	12	1
					FRINGE BENEFITS-HEALTH PLAN				
26000057	2	SPOUSE	1,110.00		01-900-001-8104		Expenditure	13	1
					FRINGE BENEFITS-HEALTH PLAN				
			2,220.00						
272	02/17/26	NJSH0010 NJSHBP							2217
26000018	4	ACTIVE EMPLOYEES HEALTH	43,274.56		01-900-001-8104		Expenditure	1	1
					FRINGE BENEFITS-HEALTH PLAN				
26000018	5	RETIRED EMPLOYEES HEALTH	21,637.28		01-900-001-8104		Expenditure	2	1
					FRINGE BENEFITS-HEALTH PLAN				
			64,911.84						
Checking Account Totals			<u>Paid</u>	<u>Void</u>	<u>Amount Paid</u>		<u>Amount</u>	<u>Void</u>	
		Checks:	1	3	64,911.84			2,220.00	
		Direct Deposit:	0	0	0.00			0.00	
		Total:	1	3	64,911.84			2,220.00	
OPERATIONS Operating Account									
18534	01/22/26	EZPAS010 EZ PASS							2218
26000029	2	EZ PASS	240.00		01-900-001-8605		Expenditure	1	1
					MISCELLANEOUS				
18535	01/22/26	DELTA005 DELTA DENTAL OF NEW JERSEY,INC							2219
26000025	3	DENTAL INSURANCE - FEB	1,435.80		01-900-001-8105		Expenditure	1	1
					FRINGE BENEFITS-DENTAL PLAN				
18536	01/26/26	COMCA005 COMCAST							2220
26000021	5	PHONE & INTERNET - FEB	312.78		01-900-003-7901		Expenditure	1	1
					TELEPHONE-DISPOSAL				
26000021	6	PHONE & INTERNET - FEB	303.76		01-900-001-7901		Expenditure	2	1
					TELEPHONE-OFFICE				
			616.54						
18482	01/29/26	EZPAS010 EZ PASS			(Void Reason: DATE ERROR)	01/29/26	VOID		2193
25000029	16	EZ PASS	240.00		01-900-001-7405		Expenditure	1	1
					AUTO,TRUCK-MISC.-ADM.				
18537	01/29/26	POST0015 POSTMASTER- RED BANK							2221
26000128	1	ANNUAL BILLING - 2026	5,712.52		01-900-001-8300		Expenditure	1	1
					OFFICE EXPENSES				

Check #	Check Date	Vendor	Amount Paid	Charge Account	Account Type	Reconciled/Void Contract	Ref Num	Ref Seq	Acct
PO #	Item	Description							
OPERATIONS Operating Account			Continued						
18538	02/02/26	USBAN005 U.S. BANK NA					2222		
26000129	1	2010A ARRA INTEREST	18,160.00	01-900-001-6510	Expenditure		1	1	
				DEBT SERVICE EXPENSE-INTEREST					
26000129	2	2010A ARRA PRINCIPAL	93,000.00	01-900-001-6500	Expenditure		2	1	
				DEBT SERVICE EXPENSE-PRINCIPAL					
26000129	3	2010A ARRA ADMIN FEE	5,130.00	01-900-001-8001	Expenditure		3	1	
				TRUSTEE FEES					
26000129	4	2010A INTEREST	6,080.00	01-900-001-6510	Expenditure		4	1	
				DEBT SERVICE EXPENSE-INTEREST					
26000129	5	2010A PRINCIPAL	59,761.54	01-900-001-6510	Expenditure		5	1	
				DEBT SERVICE EXPENSE-INTEREST					
26000129	6	2010A ADMIN FEE	1,725.00	01-900-001-8001	Expenditure		6	1	
				TRUSTEE FEES					
26000129	7	2025 A-SW1/C-SW1 INTEREST	21,790.83	01-900-001-6510	Expenditure		7	1	
				DEBT SERVICE EXPENSE-INTEREST					
26000129	8	2025 A-SW1/C-SW1 PRINCIPAL	3,089.25	01-900-001-6500	Expenditure		8	1	
				DEBT SERVICE EXPENSE-PRINCIPAL					
26000129	9	2025 A-SW1/C-SW1 ADMIN FEE	1,334.16	01-900-001-8001	Expenditure		9	1	
				TRUSTEE FEES					
26000129	10	2025 A-SW1/C-SW1 INTEREST	31,596.63	01-900-001-6510	Expenditure		10	1	
				DEBT SERVICE EXPENSE-INTEREST					
26000129	11	2025 A-SW1/C-SW1 PRINCIPAL	4,868.06	01-900-001-6500	Expenditure		11	1	
				DEBT SERVICE EXPENSE-PRINCIPAL					
26000129	12	2025 A-SW1/C-SW1 ADMIN FEE	3,693.94	01-900-001-6500	Expenditure		12	1	
				DEBT SERVICE EXPENSE-PRINCIPAL					
			<u>250,229.41</u>						
18539	02/09/26	INDEE005 INDEED FOR EMPLOYERS					2223		
26000130	1	EMPLOYEE JOB POSTINGS	179.84	01-900-001-8300	Expenditure		1	1	
				OFFICE EXPENSES					
18540	02/12/26	DIVIS005 DIVISION OF STATE POLICE-SBIS					2224		
26000119	1	BACKGROUND CHECK - B.LILIENKAMP	20.00	01-900-001-8605	Expenditure		1	1	
				MISCELLANEOUS					
26000119	2	BACKGROUND CHECK - K.MCNELIS	20.00	01-900-001-8605	Expenditure		2	1	
				MISCELLANEOUS					
			<u>40.00</u>						
18541	02/12/26	EZPAS010 EZ PASS					2225		
26000029	3	EZ PASS	240.00	01-900-001-8605	Expenditure		1	1	
				MISCELLANEOUS					
18542	02/17/26	LBSEW005 L.B.SEWERAGE AUTH.PAYROLL					2226		
26000125	1	PAYPERIOD END 1/17 D.D.	44,012.77	01-000-001-1021	G/L		1	1	
				P/R CK'G #100024660-CJB					
26000125	2	TAXES	22,882.71	01-000-001-1021	G/L		2	1	
				P/R CK'G #100024660-CJB					
26000125	3	EMPLOYEE DEDUCTIONS	23.79	01-000-001-1021	G/L		3	1	
				P/R CK'G #100024660-CJB					
			<u>66,919.27</u>						

Check #	Check Date	Vendor	Amount Paid	Charge Account	Account Type	Reconciled/Void Contract	Ref Num	Ref Seq	Acct
PO #	Item	Description							
OPERATIONS			Continued						
18543	02/17/26	LBSEW005 L.B.SEWERAGE AUTH.PAYROLL					2227		
26000131	1	PAYPERIOD END 1/31 D.D.	46,745.35	01-000-001-1021 P/R CK'G #100024660-CJB	G/L		1	1	
26000131	2	TAXES	24,399.30	01-000-001-1021 P/R CK'G #100024660-CJB	G/L		2	1	
26000131	3	EMPLOYEE DEDUCTIONS	23.79	01-000-001-1021 P/R CK'G #100024660-CJB	G/L		3	1	
			<u>71,168.44</u>						

Checking Account Totals	Paid	Void	Amount Paid	Amount Void
Checks:	10	1	396,781.82	240.00
Direct Deposit:	0	0	0.00	0.00
Total:	<u>10</u>	<u>1</u>	<u>396,781.82</u>	<u>240.00</u>

PAYROLL			PAYROLL CHECKING						
735	01/22/26	INTER005 INTERNAL REVENUE SERVICE					2228		
26000126	1	FEDERAL TAXES PERIOD END 1/17	7,472.71	01-500-001-1820 FEDERAL WITHHOLDING PAYABLE	G/L		1	1	
26000126	2	FICA EMPLOYEE	5,332.99	01-500-001-1820 FEDERAL WITHHOLDING PAYABLE	G/L		2	1	
26000126	3	FICA EMPLOYER	5,333.03	01-900-001-8101 FRINGE BENEFITS-FICA	Expenditure		3	1	
26000126	4	FEDERAL UNEMPLOYMENT	236.39	01-900-001-8101 FRINGE BENEFITS-FICA	Expenditure		4	1	
			<u>18,375.12</u>						

736	01/22/26	NJST0010 NJ STATE GROSS INCOME TAX					2228		
26000127	1	STATE TAXES PERIOD END 1/17	3,296.42	01-500-001-1830 N.J. WITHHOLDING TAX PAYABLE	G/L		5	1	
26000127	2	NJ SUI/SDI EMPLOYEE	641.63	01-500-001-1840 SUI, SDI PAYABLE-EMPLOYEE	G/L		6	1	
26000127	3	NJ SUI/SDI EMPLOYER	569.54	01-900-001-8102 FRINGE BENEFITS-SUI & SDI	Expenditure		7	1	
			<u>4,507.59</u>						

737	02/05/26	INTER005 INTERNAL REVENUE SERVICE					2229		
26000133	1	FEDERAL TAXES PERIOD END 1/31	8,223.46	01-500-001-1820 FEDERAL WITHHOLDING PAYABLE	G/L		4	1	
26000133	2	FICA EMPLOYEE	5,641.46	01-500-001-1810 FICA PAYABLE-EMPLOYEE	G/L		5	1	
26000133	3	FICA EMPLOYER	5,641.48	01-900-001-8101 FRINGE BENEFITS-FICA	Expenditure		6	1	
26000133	4	FEDERAL UNEMPLOYMENT	54.66	01-900-001-8102 FRINGE BENEFITS-SUI & SDI	Expenditure		7	1	
			<u>19,561.06</u>						

738	02/05/26	NJST0010 NJ STATE GROSS INCOME TAX					2229		
26000132	1	STATE TAXES PERIOD END 1/31	3,564.16	01-500-001-1830 N.J. WITHHOLDING TAX PAYABLE	G/L		1	1	
26000132	2	NJ SUI/SDI EMPLOYEE	674.99	01-500-001-1840 SUI, SDI PAYABLE-EMPLOYEE	G/L		2	1	

---

Check #	Check Date	Vendor	Amount Paid	Charge Account	Reconciled/Void	Ref Num
PO #	Item	Description			Account Type	Contract Ref Seq Acct

---

PAYROLL	PAYROLL CHECKING		Continued			
738 NJ STATE	GROSS INCOME TAX	Continued				
26000132	3 NJ SUI/SDI EMPLOYER		599.09	01-900-001-8102	Expenditure	3 1
			<u>4,838.24</u>	FRINGE BENEFITS-SUI & SDI		

Checking Account Totals	<u>Paid</u>	<u>Void</u>	<u>Amount Paid</u>	<u>Amount Void</u>
Checks:	4	0	47,282.01	0.00
Direct Deposit:	<u>0</u>	<u>0</u>	<u>0.00</u>	<u>0.00</u>
Total:	4	0	47,282.01	0.00

---

Report Totals	<u>Paid</u>	<u>Void</u>	<u>Amount Paid</u>	<u>Amount Void</u>
Checks:	27	5	530,166.13	2,460.00
Direct Deposit:	<u>0</u>	<u>0</u>	<u>0.00</u>	<u>0.00</u>
Total:	27	5	530,166.13	2,460.00

---

---

Totals by Year-Fund Fund Description	Fund	Expend Total	Revenue Total	G/L Total	Total
	6-01	336,040.14	0.00	172,935.53	508,975.67
Total of All Funds:		<u>336,040.14</u>	<u>0.00</u>	<u>172,935.53</u>	<u>508,975.67</u>

---

Totals by Fund					
Fund Description	Fund	Expend Total	Revenue Total	G/L Total	Total
	01	336,040.14	0.00	172,935.53	508,975.67
Total of All Funds:		<u>336,040.14</u>	<u>0.00</u>	<u>172,935.53</u>	<u>508,975.67</u>

Fund Description	Fund	Current	Prior Rcvd	Prior Open	Paid Prior	Fund Total
	6-01	336,040.14	0.00	0.00	0.00	336,040.14
Total of All Funds:		<u>336,040.14</u>	<u>0.00</u>	<u>0.00</u>	<u>0.00</u>	<u>336,040.14</u>

Project Description	Project No.	Project Total
650 WOODGATE AVE	100-38-01	525.00
335-345 SECOND AVE	LBS-0339	6,030.00
LOWER BROADWAY	LBS-295	237.50
THE ATLANTIC CLUB	LBS-334	2,054.90
83 NORTH BROADWAY	LBS-357	490.00
665 SECOND AVE	LBS0336	2,297.50
665 SECOND AVE	LBS0336 MB	8,763.06
213 LENOX AVENUE	LBS0345	160.00
112 BRIGHTON AVE	LBS0350	142.50
305 BROADWAY	LBS0353	490.00
Total of All Projects:		<u>21,190.46</u>

Long Branch Sewerage Authority  
Bill List By Vendor Name

Ranges		Item Status		Purchase Types		Misc				
<i>Range: First to Last</i> <i>Rcvd Batch Id Range: First to Last</i>		<i>Open: N</i> <i>Void: N</i> <i>Paid: N</i> <i>Held: Y</i> <i>Aprv: N</i> <i>Rcvd: Y</i>		<i>Bid: Y</i> <i>State: Y</i> <i>Other: Y</i> <i>Exempt: Y</i>		<i>P.O. Type: All</i> <i>Include Project Line Items: Yes</i> <i>Format: Detail without Line Item Notes</i> <i>Include Non-Budgeted: Y</i> <i>Prior Year Only: N</i> <i>* Means Prior Year Line:</i> <i>Vendors: All</i>				
Vendor #	Name	Description		Contract	PO Type	First Enc Rcvd		Chk/Void	Invoice	1099 Excl
P.O. #	PO Date	Amount	Charge Account	Acct Description	Stat/Chk	Date	Date	Date		
Item Description				Type						
ALLI0010	ALLIED FIRE & SAFETY EQUIP INC									
26000122	01/27/26	FIRE EXTINGUISHER SERVICE								
1 FIRE EXTINGUISHER SERVICE		\$735.00	01-900-003-7101	E	REPAIRS AND SUPPLIES-DISPOSAL R	01/27/26	02/13/26		017923	N
<b>Vendor Total:</b>		<b>\$735.00</b>								
ASBUR005	ASBURY PARK PRESS									
25000612	12/24/25	AUDIT SYNOPSIS								
1 AUDIT SYNOPSIS		\$318.50	01-900-001-8604	E	ADVERTISING-MEETINGS & BIDS R	12/24/25	12/31/25		7481711	N
26000114	01/08/26	LEGAL ADS - JAN 2026								
1 LEGAL ADS - JAN 2026		\$215.56	01-900-001-8604	E	ADVERTISING-MEETINGS & BIDS R	01/08/26	02/12/26		7529404	N
<b>Vendor Total:</b>		<b>\$534.06</b>								
ATLAN005	ATLANTIC PLUMB SUPPLY INC									
26000081	01/02/26	2026 BLANKET			B					
4 BRASS PLUG, GASKET		\$41.90	01-900-003-7101	E	REPAIRS AND SUPPLIES-DISPOSAL R	01/02/26	02/17/26		S4545817	N
5 BALL VALVE, GALV. NIPPLE		\$23.44	01-900-003-7101	E	REPAIRS AND SUPPLIES-DISPOSAL R	01/02/26	02/17/26		S4547351	N
6 BLACK NIPPLES, 1/2 COUPLING		\$5.52	01-900-003-7101	E	REPAIRS AND SUPPLIES-DISPOSAL R	01/02/26	02/17/26		S4547595	N
7 MAL PLUG, BALL VALVE		\$18.77	01-900-003-7101	E	REPAIRS AND SUPPLIES-DISPOSAL R	01/02/26	02/17/26		S4554049	N
8 GALV NIPPLES		\$84.55	01-900-003-7101	E	REPAIRS AND SUPPLIES-DISPOSAL R	01/02/26	02/17/26		S4560495	N
9 BUSHINGS		\$63.52	01-900-003-7101	E	REPAIRS AND SUPPLIES-DISPOSAL R	01/02/26	02/17/26		S4560580	N
		<b>\$237.70</b>								
<b>Vendor Total:</b>		<b>\$237.70</b>								
CANNO005	CANNON & MCGUINN, LLC									
25000613	11/30/25	LABOR ATTORNEY - NOVEMBER								
1 LABOR ATTORNEY - NOVEMBER		\$82.50	01-900-001-8010	E	LEGAL-LABOR RELATIONS R	11/30/25	12/31/25		431	N
25000614	12/31/25	PERSONNEL POLICY REVISIONS								
1 PERSONNEL POLICY REVISIONS		\$1,039.50	01-900-001-8010	E	LEGAL-LABOR RELATIONS R	12/31/25	12/31/25		459	N
<b>Vendor Total:</b>		<b>\$1,122.00</b>								
CHARL005	CHARLES BOYD									

**Long Branch Sewerage Authority**  
Bill List By Vendor Name

Vendor #	Name	Description		Contract	PO Type	Stat/Chk	First Enc Date	Rcvd Date	Chk/Void Date	Invoice	1099 Excl
P.O. #	PO Date	Amount	Charge Account	Acct Description	Type						
Item Description											
CHARL005	CHARLES BOYD	Account Continued									
26000063	01/15/26	SEMI ANNUAL MEDICARE REIMBURSE									
1 SEMI ANNUAL MEDICARE REIMBUR		\$1,110.00	01-900-001-8104	E	FRINGE BENEFITS-HEALTH PLAN	R	02/13/26	02/17/26			N
<b>Vendor Total:</b>		<b>\$1,110.00</b>									
CHESA005	CHESAPEAKE EXTERMINATING										
26000079	01/02/26	PEST CONTROL BLANKET									
2 PEST CONTROL-JAN		\$80.00	01-900-001-8300	E	OFFICE EXPENSES	R	01/02/26	02/12/26			N
<b>Vendor Total:</b>		<b>\$80.00</b>									
CITYO015	CITY OF ASBURY PARK										
26000115	01/21/26	2026 CONFINED SPACE RESCUE SVC									
1 2026 CONFINED SPACE RESCUE SV		\$19,331.50	01-900-003-7101	E	REPAIRS AND SUPPLIES-DISPOSAL	R	01/21/26	02/17/26		2026-04	N
<b>Vendor Total:</b>		<b>\$19,331.50</b>									
COLLI005	COLLIERS ENGINEERING & DESIGN										
26000118	02/01/26	ENGINEERING - FEBRUARY									
1 ENGINEERING - FEBRUARY		\$2,098.64	01-900-001-8002	E	ENGINEERING	R	02/01/26	02/17/26		1141832	N
2 HOSTING FEE DEC		\$500.00	01-900-001-8002	E	ENGINEERING	R	02/01/26	02/17/26		1130513	N
3 eGIS/GPS PROGRAM SVCS		\$5,000.00	01-900-001-8002	E	ENGINEERING	R	02/01/26	02/17/26		1130512	N
4 HOEY PUMP STATION IMPROV.		\$6,748.60	01-900-001-8002	E	ENGINEERING	R	02/01/26	02/17/26		1141833	N
		<u>\$14,347.24</u>									
<b>Vendor Total:</b>		<b>\$14,347.24</b>									
COOPE005	COOPER ELECTRIC SUPPLY CO										
26000082	01/02/26	2026 BLANKET									
3 SCREWDRIVE KIT, CANVAS BAGS		\$89.41	01-900-003-7101	E	REPAIRS AND SUPPLIES-DISPOSAL	R	01/02/26	02/12/26		S060941498.001	N
4 BATTERY PACKS,HEX KEY SET,VOL		\$516.95	01-900-003-7101	E	REPAIRS AND SUPPLIES-DISPOSAL	R	01/02/26	02/12/26		S060964717.001	N
		<u>\$606.36</u>									
<b>Vendor Total:</b>		<b>\$606.36</b>									
DELIS005	DELISA DEMOLITION & DISPOSAL										
26000078	01/02/26	TRASH REMOVAL - 2026 BLANKET									
2 TRASH REMOVAL - FEBRUARY		\$195.30	01-900-003-7101	E	REPAIRS AND SUPPLIES-DISPOSAL	R	01/02/26	02/13/26		364225	N
<b>Vendor Total:</b>		<b>\$195.30</b>									
ELECT005	ELECTRO MAINTENANCE INC										
26000083	01/02/26	2026 BLANKET									

**Long Branch Sewerage Authority**  
Bill List By Vendor Name

Vendor #	Name	Description		Contract	PO Type	Stat/Chk	First Enc Date	Rcvd Date	Chk/Void Date	Invoice	1099 Excl
P.O. #	PO Date	Amount	Charge Account	Acct Description	Type						
Item Description											
ELECT005	ELECTRO MAINTENANCE INC	<i>Account Continued</i>									
3 ELECTRICAL REPAIRS	11/17/25	\$761.00	01-900-003-7101	E	REPAIRS AND SUPPLIES-DISPOSAL	R	01/02/26	02/12/26		14752	N
<b>Vendor Total:</b>		<b>\$761.00</b>									
FEDER005	FEDERAL EXPRESS CORP.										
26000113	01/23/26	DOCUMENTS TO D. RILEY									
1 DOCUMENTS TO D. RILEY		\$58.15	01-900-001-8300	E	OFFICE EXPENSES	R	01/23/26	02/12/26		9-170-02770	N
<b>Vendor Total:</b>		<b>\$58.15</b>									
FISHE005	FISHER SCIENTIFIC INC.										
26000009	01/01/26	LAB SUPPLIES/EQUIPMENT-BLANKET									
2 LAB SUPPLIES - JAN		\$133.37	01-900-003-7102	E	REPAIRS & SUPPLIES - LAB	R	01/01/26	02/12/26		5977681	N
3 LAB SUPPLIES - JAN		\$28.81	01-900-003-7102	E	REPAIRS & SUPPLIES - LAB	R	01/01/26	02/12/26		6100196	N
		<b>\$162.18</b>									
<b>Vendor Total:</b>		<b>\$162.18</b>									
FRANS005	FRANCES SORRENTINO										
26000060	01/01/26	SEMI ANNUAL MEDICARE REIMBURSE									
1 SEMI ANNUAL MEDICARE REIMBUR		\$1,110.00	01-900-001-8104	E	FRINGE BENEFITS-HEALTH PLAN	R	01/01/26	01/16/26			N
<b>Vendor Total:</b>		<b>\$1,110.00</b>									
FRANK005	FRANK BLAISDELL										
26000057	01/01/26	SEMI ANNUAL MEDICARE REIMBURSE									
1 SEMI ANNUAL MEDICARE REIMBUR		\$1,110.00	01-900-001-8104	E	FRINGE BENEFITS-HEALTH PLAN	R	01/01/26	01/16/26			N
2 SPOUSE		\$1,110.00	01-900-001-8104	E	FRINGE BENEFITS-HEALTH PLAN	R	01/01/26	01/16/26			N
		<b>\$2,220.00</b>									
<b>Vendor Total:</b>		<b>\$2,220.00</b>									
FREEH005	FREEHOLD CARTAGE INC										
26000005	01/01/26	SLUDGE & GRIT - BLANKET									
3 GRIT REMOVAL - JANUARY		\$1,848.00	01-900-003-7300	E	GRIT REMOVAL	R	01/22/26	02/13/26		2394769	N
4 GRIT REMOVAL - JANUARY		\$1,848.00	01-900-003-7300	E	GRIT REMOVAL	R	01/22/26	02/13/26		2395010	N
		<b>\$3,696.00</b>									
<b>Vendor Total:</b>		<b>\$3,696.00</b>									
GAILK005	GAIL KANE										
26000051	01/01/26	SEMI ANNUAL MEDICARE REIMBURSE									
1 SEMI ANNUAL MEDICARE REIMBUR		\$1,110.00	01-900-001-8104	E	FRINGE BENEFITS-HEALTH PLAN	R	01/01/26	01/16/26			N

**Long Branch Sewerage Authority**  
Bill List By Vendor Name

Vendor #	Name	Description		Contract	PO Type	Stat/Chk	First Enc Date	Rcvd Date	Chk/Void Date	Invoice	1099 Excl
P.O. #	PO Date	Amount	Charge Account	Acct Description Type							
Item Description											
GAILK005	GAIL KANE	Account Continued									
<b>Vendor Total:</b>		<b>\$1,110.00</b>									
GARDE005	GARDEN STATE LABS INC										
26000007	01/01/26	CONTRACT LAB SERVICES			B						
2 LAB SERVICES - JANUARY		\$574.00	01-900-003-7102	E	REPAIRS & SUPPLIES - LAB	R	01/01/26	02/13/26		603423	N
<b>Vendor Total:</b>		<b>\$574.00</b>									
GRAIN005	GRAINGER INC.										
26000010	01/01/26	VARIOUS SUPPLIES - BLANKET			B						
4 RUBBER ROLL		\$212.29	01-900-003-7101	E	REPAIRS AND SUPPLIES-DISPOSAL	R	01/02/26	02/17/26		9757688206	N
5 EPDM SHEET		\$74.12	01-900-003-7101	E	REPAIRS AND SUPPLIES-DISPOSAL	R	01/02/26	02/17/26		5759559504	N
6 ASSORTED SUPPLIES		\$1,314.75	01-900-003-7101	E	REPAIRS AND SUPPLIES-DISPOSAL	R	01/02/26	02/17/26		9761295717	N
7 ELECTRIC AIR COMPRESSOR		\$3,102.63	01-900-003-7101	E	REPAIRS AND SUPPLIES-DISPOSAL	R	01/02/26	02/17/26		9761968081	N
8 VARIOUS TOOLS		\$321.82	01-900-003-7101	E	REPAIRS AND SUPPLIES-DISPOSAL	R	01/02/26	02/17/26		9765371076	N
9 BUSHINGS, COUPLING BODY		\$251.70	01-900-003-7101	E	REPAIRS AND SUPPLIES-DISPOSAL	R	01/02/26	02/17/26		9767874325	N
10 COMP. PRESSURE SWITCH		\$43.86	01-900-003-7101	E	REPAIRS AND SUPPLIES-DISPOSAL	R	01/02/26	02/17/26		9782689617	N
11 8" LOCK		\$374.52	01-900-003-7101	E	REPAIRS AND SUPPLIES-DISPOSAL	R	01/02/26	02/17/26		9785045296	N
12 HITCH PIN		\$125.04	01-900-003-7101	E	REPAIRS AND SUPPLIES-DISPOSAL	R	01/02/26	02/17/26		9784905383	N
13 FUEL FILTERS		\$469.92	01-900-003-7101	E	REPAIRS AND SUPPLIES-DISPOSAL	R	01/02/26	02/17/26		9789221935	N
14 HEATERS		\$1,900.71	01-900-003-7101	E	REPAIRS AND SUPPLIES-DISPOSAL	R	01/02/26	02/17/26		9790369335	N
		<b>\$8,191.36</b>									
<b>Vendor Total:</b>		<b>\$8,191.36</b>									
GREGW005	GREG W. MARRA										
26000055	01/01/26	SEMI ANNUAL MEDICARE REIMBURSE									
1 SEMI ANNUAL MEDICARE REIMBUR		\$1,110.00	01-900-001-8104	E	FRINGE BENEFITS-HEALTH PLAN	R	01/01/26	01/16/26			N
<b>Vendor Total:</b>		<b>\$1,110.00</b>									
H20SO005	H2O SOLUTIONS,INC										
26000015	01/01/26	LAB WATER MAINTENANCE-BLANKET			B						
2 LAB WATER - JAN		\$262.40	01-900-003-7102	E	REPAIRS & SUPPLIES - LAB	R	01/01/26	02/12/26		138978	N
3 FILTER HOUSING		\$106.30	01-900-003-7102	E	REPAIRS & SUPPLIES - LAB	R	01/01/26	02/12/26		139185	N
		<b>\$368.70</b>									
<b>Vendor Total:</b>		<b>\$368.70</b>									
HOMED005	HOME DEPOT CREDIT SERVICES										
26000112	01/23/26	ICE MELT & SPREADER									





Long Branch Sewerage Authority  
Bill List By Vendor Name

Vendor #	Name	Description		Contract	PO Type	Stat/Chk	First Enc Date	Rcvd Date	Chk/Void Date	Invoice	1099 Excl
P.O. #	PO Date	Amount	Charge Account	Acct Description	Type						
Item Description											
LAURI005	Laurie Hartnett	Account Continued									
<b>Vendor Total:</b>		<b>\$2,220.00</b>									
LOCAL005	LOCAL 32 OPEIU										
26000123	02/13/26	WHITE COLLAR UNION DUES - JAN									
1 WHITE COLLAR UNION DUES - JAN		\$312.00	01-500-001-1871	G	OPEIU-DUES PAYABLE	R	02/13/26	02/17/26			N
<b>Vendor Total:</b>		<b>\$312.00</b>									
LOUAN005	LOUANNE WHITE										
26000058	01/01/26	SEMI ANNUAL MEDICARE REIMBURSE									
1 SEMI ANNUAL MEDICARE REIMBUR		\$1,110.00	01-900-001-8104	E	FRINGE BENEFITS-HEALTH PLAN	R	01/01/26	01/16/26			N
<b>Vendor Total:</b>		<b>\$1,110.00</b>									
LOUIS005	LOUIS N. CHIAFULLO										
26000062	01/15/26	SEMI ANNUAL MEDICARE REIMBURSE									
1 MEDICARE REIMBURSEMENT		\$2,885.40	01-900-001-8104	E	FRINGE BENEFITS-HEALTH PLAN	R	01/16/26	02/17/26			N
2 SPOUSE		\$480.90	01-900-001-8104	E	FRINGE BENEFITS-HEALTH PLAN	R	01/16/26	02/17/26			N
		<b>\$3,366.30</b>									
<b>Vendor Total:</b>		<b>\$3,366.30</b>									
LYONS005	LYONS ENVIRONMENTAL SERVICES										
26000006	01/01/26	CONTRACT LAB SERVICES -BLANKET									
2 ENTROCCI ANALYSIS - JANUARY		\$360.00	01-900-003-7102	E	REPAIRS & SUPPLIES - LAB	R	01/02/26	02/13/26	LBSA0126		N
<b>Vendor Total:</b>		<b>\$360.00</b>									
MANNA005	MANNA & BONELLO PA										
26000120	01/01/26	LEGAL SERVICES - JANUARY 2026									
1 LEGAL SERVICES - JANUARY 2026		\$1,575.00	01-900-001-8008	E	LEGAL	R	01/01/26	02/13/26	10001		N
<b>Vendor Total:</b>		<b>\$1,575.00</b>									
MYRAB005	MYRA BUCK										
26000053	01/01/26	SEMI ANNUAL MEDICARE REIMBURSE									
1 SEMI ANNUAL MEDICARE REIMBUR		\$1,110.00	01-900-001-8104	E	FRINGE BENEFITS-HEALTH PLAN	R	01/01/26	01/16/26			N
<b>Vendor Total:</b>		<b>\$1,110.00</b>									
NAPAA005	NAPA AUTO PARTS										
26000093	01/02/26	2026 BLANKET									
6 OIL		\$34.10	01-900-003-7401	E	AUTO,TRUCK-REPAIR/PARTS-DISP.	R	01/02/26	02/17/26	506152		N
7 OIL RETURN		34.10	01-900-003-7401	E	AUTO,TRUCK-REPAIR/PARTS-DISP.	R	01/02/26	02/17/26	506183		N

Long Branch Sewerage Authority  
Bill List By Vendor Name

Vendor #	Name	Description		Contract	PO Type	First Enc Date	Rcvd Date	Chk/Void Date	Invoice	1099 Excl
P.O. #	PO Date	Amount	Charge Account	Acct Description Type	Stat/Chk					
<b>NAPAA005</b>										
NAPA AUTO PARTS		<i>Account Continued</i>								
8	JUMPER CABLE, WASHER FLUID	\$84.21	01-900-003-7101	E	REPAIRS AND SUPPLIES-DISPOSAL R	01/02/26	02/17/26		072851	N
9	START FLUID, CARB-CHOKE CLEAN	\$8.83	01-900-003-7101	E	REPAIRS AND SUPPLIES-DISPOSAL R	01/02/26	02/17/26		073496	N
10	NAPA 5 GAL OIL	\$79.17	01-900-003-7101	E	REPAIRS AND SUPPLIES-DISPOSAL R	01/02/26	02/17/26		073621	N
11	SUPER HC IND V BELT	\$42.66	01-900-003-7101	E	REPAIRS AND SUPPLIES-DISPOSAL R	01/02/26	02/17/26		070496	N
12	CORE DEPOSIT	168.00-	01-900-003-7101	E	REPAIRS AND SUPPLIES-DISPOSAL R	01/02/26	02/17/26		069611	N
		<b>\$46.87</b>								
<b>Vendor Total:</b>		<b>\$46.87</b>								
<b>NEWJE005</b>										
NEW JERSEY AMERICAN WATER										
26000023	01/01/26	WATER - BLANKET		B						
3	JOLINE AVE	\$450.80	01-900-003-7801	E	WATER - PLANT - JOLINE AVENUE R	01/02/26	02/17/26			N
4	JOLINE AVE	\$641.31	01-900-003-7801	E	WATER - PLANT - JOLINE AVENUE R	01/02/26	02/17/26			N
5	SEAVIEW AVE MUNGARAGE	\$319.36	01-900-003-7801	E	WATER - PLANT - JOLINE AVENUE R	01/02/26	02/17/26			N
6	LINCOLN GARDENS PS	\$26.00	01-900-004-7802	E	WATER- PUMP STATIONS R	01/02/26	02/17/26			N
7	OVERLOOK AVE PS	\$26.00	01-900-004-7802	E	WATER- PUMP STATIONS R	01/02/26	02/17/26			N
8	WILLOW AVE PS	\$64.97	01-900-004-7802	E	WATER- PUMP STATIONS R	01/02/26	02/17/26			N
9	OCEAN AVE PS	\$26.00	01-900-004-7802	E	WATER- PUMP STATIONS R	01/02/26	02/17/26			N
		<b>\$1,554.44</b>								
<b>Vendor Total:</b>		<b>\$1,554.44</b>								
<b>NJNAT005</b>										
NJ NATURAL GAS CO.										
26000024	01/01/26	NATURAL GAS - BLANKET		B						
3	150 JOLINE AVE	\$8,867.85	01-900-003-7602	E	HEAT-GAS R	01/02/26	02/17/26			N
4	150 JOLINE AVE	\$63.00	01-900-003-7602	E	HEAT-GAS R	01/02/26	02/17/26			N
5	UTILITY BUILDING	\$4,093.17	01-900-003-7602	E	HEAT-GAS R	01/02/26	02/17/26			N
6	HOEY & OVERLOOK AVE PS	\$134.00	01-900-004-7101	E	REPAIRS AND SUPPLIES-PUMPING R	01/02/26	02/17/26			N
7	LINCOLN GARDENS PS	\$114.50	01-900-004-7101	E	REPAIRS AND SUPPLIES-PUMPING R	01/02/26	02/17/26			N
8	MCCLELLAN ST PS	\$56.86	01-900-004-7101	E	REPAIRS AND SUPPLIES-PUMPING R	01/02/26	02/17/26			N
9	MONMOUTH PL PS	\$110.83	01-900-004-7101	E	REPAIRS AND SUPPLIES-PUMPING R	01/02/26	02/17/26			N
10	WILLOW AVE PS	\$55.00	01-900-004-7101	E	REPAIRS AND SUPPLIES-PUMPING R	01/02/26	02/17/26			N
		<b>\$13,495.21</b>								
<b>Vendor Total:</b>		<b>\$13,495.21</b>								
<b>ONECA005</b>										
ONE CALL CONCEPTS INC.										
26000094	01/02/26	2026 BLANKET		B						

**Long Branch Sewerage Authority**  
Bill List By Vendor Name

Vendor #	Name	Description		Contract	PO Type	Stat/Chk	First Enc Date	Rcvd Date	Chk/Void Date	Invoice	1099 Excl
P.O. #	PO Date	Amount	Charge Account	Acct Description Type							
ONECA005	ONE CALL CONCEPTS INC.	Account Continued									
2 MARK OUTS - JANUARY		\$473.10	01-900-002-7101	E	REPAIRS & SUPPLIES-COLLECTION	R	01/02/26	02/13/26		6015399	N
<b>Vendor Total:</b>		<b>\$473.10</b>									
PILOT005	PILOT ELECTRIC CO. INC.										
26000095	01/02/26	2026 BLANKET PO				B					
3 REPAIR TO MOTOR ON PUMP		\$3,868.75	01-900-003-7101	E	REPAIRS AND SUPPLIES-DISPOSAL	R	01/02/26	02/13/26		70106	N
<b>Vendor Total:</b>		<b>\$3,868.75</b>									
POLYD005	POLYDYNE INC.										
26000003	01/01/26	DRY & EMULSION POLYMER-BLANKET				B					
2 CLARIFLOC NE-203		\$7,406.00	01-900-003-7503	E	CHEMICALS-POLYMER	R	01/01/26	02/13/26		1996280	N
<b>Vendor Total:</b>		<b>\$7,406.00</b>									
RACHL005	RACHLES/MICHELE'S OIL COMPANY										
26000102	01/02/26	2026 BLANKET GAS & DIESEL				B					
5 GAS - JANUARY		\$318.52	01-900-002-7402	E	AUTO,TRUCK-GASOLINE-COLL.	R	01/02/26	02/17/26		447491	N
6 GAS - JANUARY		\$637.04	01-900-003-7402	E	AUTO,TRUCK-GASOLINE-DISP.	R	01/02/26	02/17/26		447491	N
7 GAS - JANUARY		\$318.52	01-900-001-7402	E	AUTO,TRUCK-GASOLINE-ADM.	R	01/02/26	02/17/26		447491	N
		<b>\$1,274.08</b>									
<b>Vendor Total:</b>		<b>\$1,274.08</b>									
NANCY005	ROBERT FAYE										
26000061	01/01/26	SEMI ANNUAL MEDICARE REIMBURSE									
1 SEMI ANNUAL MEDICARE REIMBUR		\$1,110.00	01-900-001-8104	E	FRINGE BENEFITS-HEALTH PLAN	R	01/16/26	01/16/26			N
2 NANCY		\$555.00	01-900-001-8104	E	FRINGE BENEFITS-HEALTH PLAN	R	01/16/26	01/16/26			N
		<b>\$1,665.00</b>									
<b>Vendor Total:</b>		<b>\$1,665.00</b>									
SIPER005	SIP'S PAINT & HARDWARE										
26000106	01/02/26	2026 BLANKET				B					
4 KEYS		\$15.21	01-900-003-7101	E	REPAIRS AND SUPPLIES-DISPOSAL	R	01/02/26	02/13/26		55764	N
5 HEX CAP,FENDER WASHER,SHAFTC		\$431.05	01-900-003-7101	E	REPAIRS AND SUPPLIES-DISPOSAL	R	01/02/26	02/13/26		55761	N
6 VINYL TUBING		\$11.23	01-900-003-7101	E	REPAIRS AND SUPPLIES-DISPOSAL	R	01/02/26	02/13/26		55778	N
7 DIE HARD BOOST CABLE		\$23.49	01-900-003-7101	E	REPAIRS AND SUPPLIES-DISPOSAL	R	01/02/26	02/13/26		55778	N
8 WOOD STAKE, ORANGE SPRAYPAI		\$78.85	01-900-003-7101	E	REPAIRS AND SUPPLIES-DISPOSAL	R	01/02/26	02/13/26		55897	N
9 BLUE TARP, PARACORD		\$93.97	01-900-003-7101	E	REPAIRS AND SUPPLIES-DISPOSAL	R	01/02/26	02/13/26		55955	N
10 NIPPLES		\$12.19	01-900-003-7101	E	REPAIRS AND SUPPLIES-DISPOSAL	R	01/02/26	02/13/26		55952	N



Long Branch Sewerage Authority  
Bill List By Vendor Name

Vendor #	Name	Description		Contract	PO Type	Stat/Chk	First Enc Date	Rcvd Date	Chk/Void Date	Invoice	1099 Excl
P.O. #	PO Date	Amount	Charge Account	Acct Description Type							
UNIFI005	UNIFIRST CORPORATION	Account Continued									
3	UNIFORM RENTALS - JANUARY	\$193.46	01-900-003-7101	E	REPAIRS AND SUPPLIES-DISPOSAL R		01/02/26	02/13/26		1260861527	N
4	UNIFORM RENTALS - JANUARY	\$193.46	01-900-003-7101	E	REPAIRS AND SUPPLIES-DISPOSAL R		01/02/26	02/13/26		1260865109	N
5	UNIFORM RENTALS - JANUARY	\$193.46	01-900-003-7101	E	REPAIRS AND SUPPLIES-DISPOSAL R		01/02/26	02/13/26		1260868450	N
		<b>\$773.84</b>									
<b>Vendor Total:</b>		<b>\$773.84</b>									
UNIVA005	UNIVAR SOLUTIONS										
26000004	01/01/26	PAC	B								
2	ALUMINUM HYDROXIDE - JANUARY	\$1,316.19	01-900-003-7507	E	CHEMICAL-ALUMINUM HYDROXIDE R		01/01/26	02/13/26		53601302	N
3	ALUMINUM HYDROXIDE - JANUARY	\$1,316.19	01-900-003-7507	E	CHEMICAL-ALUMINUM HYDROXIDE R		01/01/26	02/13/26		53618102	N
		<b>\$2,632.38</b>									
<b>Vendor Total:</b>		<b>\$2,632.38</b>									
POSTM005	US POSTAL SERVICE										
26000116	02/12/26	PO BOX YEARLY RENEWAL									
1	PO BOX YEARLY RENEWAL	\$524.00	01-900-001-8300	E	OFFICE EXPENSES	R	02/12/26	02/17/26			N
<b>Vendor Total:</b>		<b>\$524.00</b>									
USABL005	USA BLUEBOOK										
26000011	01/01/26	VARIOUS SUPPLIES - BLANKET	B								
3	ASST. LAB SUPPLIES	\$510.25	01-900-003-7101	E	REPAIRS AND SUPPLIES-DISPOSAL R		01/02/26	02/13/26		INV00930254	N
4	SLUDGE JUDGE	\$259.25	01-900-003-7101	E	REPAIRS AND SUPPLIES-DISPOSAL R		01/02/26	02/13/26		INV00934771	N
5	WALCHEM EHE SERIES PUMP	\$1,711.20	01-900-003-7101	E	REPAIRS AND SUPPLIES-DISPOSAL R		01/02/26	02/13/26		INV00939953	N
6	PH BUFFER	\$151.08	01-900-003-7101	E	REPAIRS AND SUPPLIES-DISPOSAL R		01/02/26	02/13/26		INV00943859	N
7	SUBMERSIBLE LEVEL TRANSMITTE	\$855.84	01-900-002-7101	E	REPAIRS & SUPPLIES-COLLECTION R		01/02/26	02/13/26		INV00950363	N
		<b>\$3,487.62</b>									
<b>Vendor Total:</b>		<b>\$3,487.62</b>									
USWIN005	USW INTERNATIONAL UNION										
26000124	02/13/26	BLUE COLLAR UNION DUES - JAN									
1	BLUE COLLAR UNION DUES - JAN	\$741.80	01-500-001-1870	G	USW-UNION DUES	R	02/13/26	02/17/26			N
<b>Vendor Total:</b>		<b>\$741.80</b>									
WBMAS005	W.B.MASON CO.INC.										
26000111	01/02/26	2026 BLANKET	B								
3	WATER & TP	\$141.81	01-900-001-8300	E	OFFICE EXPENSES	R	01/02/26	02/17/26		259300249	N

Long Branch Sewerage Authority  
Bill List By Vendor Name

Vendor #	Name	Description		Contract	PO Type	Stat/Chk	First Enc Date	Rcvd Date	Chk/Void Date	Invoice	1099 Excl
P.O. #	PO Date	Amount	Charge Account	Acct Description	Type						
Item Description											
WBMAS005	W.B.MASON CO.INC.	Account Continued									
4 MOP HEADS, CLEANER, SOAP		\$282.51	01-900-003-7101	E	REPAIRS AND SUPPLIES-DISPOSAL	R	01/02/26	02/17/26		259546166	N
5 LEAD, WATER, COFFEE		\$100.00	01-900-001-8300	E	OFFICE EXPENSES	R	01/02/26	02/17/26		259539775	N
6 CAN LINERS		\$165.58	01-900-001-8300	E	OFFICE EXPENSES	R	01/02/26	02/17/26		259573954	N
7 PAPER, SHEET PROT.PENS,SOAP		\$66.73	01-900-001-8300	E	OFFICE EXPENSES	R	01/02/26	02/17/26		259612276	N
		<b>\$756.63</b>									
	<b>Vendor Total:</b>	<b>\$756.63</b>									
WILL0015	WILLIAM D. STEELE										
26000059	01/01/26	SEMI ANNUAL MEDICARE REIMBURSE									
1 SEMI ANNUAL MEDICARE REIMBUR		\$1,110.00	01-900-001-8104	E	FRINGE BENEFITS-HEALTH PLAN	R	01/01/26	01/16/26			N
2 SPOUSE		\$1,110.00	01-900-001-8104	E	FRINGE BENEFITS-HEALTH PLAN	R	01/01/26	01/16/26			N
		<b>\$2,220.00</b>									
	<b>Vendor Total:</b>	<b>\$2,220.00</b>									
YPERS005	Y-pers,INC.										
26000088	01/02/26	SUPPLIES BLANKET - 2026									
4 GRABBER ORANGE GLOVES		\$254.95	01-900-002-7101	E	REPAIRS & SUPPLIES-COLLECTION	R	01/02/26	02/13/26		0211993-IN	N
	<b>Vendor Total:</b>	<b>\$254.95</b>									
<b>Total Purchase Orders: 61 Total P.O. Line Items: 146 Total List Amount: \$166,288.66 Total Void Amount: \$0.00</b>											

<b>Totals by Year-Fund</b>							
<b>Fund Description</b>	<b>Fund</b>	<b>Expend Rcvd</b>	<b>Expend Held</b>	<b>Expend Total</b>	<b>Revenue Total</b>	<b>G/L Total</b>	<b>Total</b>
	5-01	\$1,440.50	\$0.00	\$1,440.50	\$0.00	\$0.00	\$1,440.50
	6-01	\$163,794.36	\$0.00	\$163,794.36	\$0.00	\$1,053.80	\$164,848.16
<b>Total Of All Funds:</b>		\$165,234.86	\$0.00	\$165,234.86	\$0.00	\$1,053.80	\$166,288.66

<b>Totals by Fund</b>							
<b>Fund Description</b>	<b>Fund</b>	<b>Expend Rcvd</b>	<b>Expend Held</b>	<b>Expend Total</b>	<b>Revenue Total</b>	<b>G/L Total</b>	<b>Total</b>
	01	\$165,234.86	\$0.00	\$165,234.86	\$0.00	\$1,053.80	\$166,288.66
<b>Total Of All Funds:</b>		\$165,234.86	\$0.00	\$165,234.86	\$0.00	\$1,053.80	\$166,288.66

**Long Branch Sewerage Authority**  
Breakdown of Expenditure Account Current/Prior Received/Prior Open

<b>Fund Description</b>	<b>Fund</b>	<b>Current</b>	<b>Prior Rcvd</b>	<b>Prior Open</b>	<b>Paid Prior</b>	<b>Fund Total</b>
	5-01	\$1,440.50	\$0.00	\$0.00	\$0.00	\$1,440.50
	6-01	\$163,794.36	\$0.00	\$0.00	\$0.00	\$163,794.36
<b>Total Of All Funds:</b>		<u>\$165,234.86</u>	<u>\$0.00</u>	<u>\$0.00</u>	<u>\$0.00</u>	<u>\$165,234.86</u>

Range of Accounts: 01-900-001-0000 to 01-900-005-9013 Include Cap Accounts: Yes As Of: 02/17/26  
Current Period: 01/22/26 to 02/17/26 Skip Zero Activity: Yes

Audit Report Type: Standard

Note: Transaction Beginning Balance includes all Adds/Changes occurring on or prior to the As of Date

\* Transaction is included in Previous and/or Begin Balance

\*\* Transaction is not included in Balance

En = PO Line Item First Encumbrance Date

BC = Blanket Control

BS = Blanket Sub

Account No	Description	Prior Budget Payable YTD	Adopted Expended YTD Expended Curr	Amended Encumber YTD	Transfers Reimbrsd YTD Reimbrsd Curr	Modified Canceled Pd/Chrgd YTD	Balance YTD Unexpended	%Used	Trans Amount	Trans Balance	User
01-900-001-0000	ADMINISTRATION										
01-900-001-5002	OFFICE SALARIES	0.00	538,433.83	0.00	0.00	538,433.83	464,146.91	14			
		0.00	74,286.92	0.00	0.00	0.00	464,146.91				
			41,541.41		0.00	74,286.92					
	Begin Balance: 01/22/26									505,688.32	
	01/22/26 Expenditure			Reference	3180	1			20,770.71-	484,917.61	MARION
	02/05/26 Expenditure			Reference	3181	1			20,770.70-	464,146.91	MARION
01-900-001-5003	OFFICERS' COMPENSATION	0.00	12,500.00	0.00	0.00	12,500.00	9,375.05	25			
		0.00	3,124.95	0.00	0.00	0.00	9,375.05				
			2,083.30		0.00	3,124.95					
	Begin Balance: 01/22/26									11,458.35	
	01/22/26 Expenditure			Reference	3180	2			1,041.65-	10,416.70	MARION
	02/05/26 Expenditure			Reference	3181	3			1,041.65-	9,375.05	MARION
01-900-001-6500	DEBT SERVICE EXPENSE-PRINCIPAL	0.00	1,112,072.00	0.00	0.00	1,112,072.00	1,007,420.75	9			
		0.00	104,651.25	0.00	0.00	0.00	1,007,420.75				
			104,651.25		0.00	104,651.25					
	Begin Balance: 01/22/26									1,112,072.00	
	02/02/26 PO 26000129 2 Paid Ck 18538			2010A ARRA PRINCIPAL	USBAN005	U.S. BANK NA	En 02/02/26		93,000.00-	1,019,072.00	MARION
	02/02/26 PO 26000129 8 Paid Ck 18538			2025 A-SW1/C-SW1 PRINCIPAL	USBAN005	U.S. BANK NA	En 02/02/26		3,089.25-	1,015,982.75	MARION
	02/02/26 PO 26000129 11 Paid Ck 18538			2025 A-SW1/C-SW1 PRINCIPAL	USBAN005	U.S. BANK NA	En 02/02/26		4,868.06-	1,011,114.69	MARION
	02/02/26 PO 26000129 12 Paid Ck 18538			2025 A-SW1/C-SW1 ADMIN FEE	USBAN005	U.S. BANK NA	En 02/02/26		3,693.94-	1,007,420.75	MARION

Account No	Description	Prior Budget Payable YTD	Adopted Expended YTD Expended Curr	Amended Encumber YTD	Transfers Reimbrsd YTD Reimbrsd Curr	Modified Canceled Pd/Chrgd YTD	Balance YTD Unexpended	%Used	Trans Amount	Trans Balance	User
01-900-001-6510	DEBT SERVICE EXPENSE-INTEREST	0.00	423,638.00	0.00	0.00	423,638.00	286,249.00	32			
		0.00	137,389.00	0.00	0.00	0.00	286,249.00				
			137,389.00		0.00	137,389.00					
	Begin Balance: 01/22/26									423,638.00	
02/02/26 PO 26000129	1 Paid Ck 18538 2010A ARRA INTEREST			USBAN005	U.S. BANK NA		En 02/02/26	18,160.00-	405,478.00	MARION	
02/02/26 PO 26000129	4 Paid Ck 18538 2010A INTEREST			USBAN005	U.S. BANK NA		En 02/02/26	6,080.00-	399,398.00	MARION	
02/02/26 PO 26000129	5 Paid Ck 18538 2010A PRINCIPAL			USBAN005	U.S. BANK NA		En 02/02/26	59,761.54-	339,636.46	MARION	
02/02/26 PO 26000129	7 Paid Ck 18538 2025 A-SW1/C-SW1 INTEREST			USBAN005	U.S. BANK NA		En 02/02/26	21,790.83-	317,845.63	MARION	
02/02/26 PO 26000129	10 Paid Ck 18538 2025 A-SW1/C-SW1 INTEREST			USBAN005	U.S. BANK NA		En 02/02/26	31,596.63-	286,249.00	MARION	
01-900-001-7401	AUTO, TRUCK-REPAIRS, PARTS-ADMIN	0.00	6,500.00	0.00	0.00	6,500.00	6,400.00	2			
		0.00	0.00	100.00	0.00	0.00	6,500.00				
			0.00		0.00	100.00					
01-900-001-7402	AUTO, TRUCK-GASOLINE-ADM.	0.00	0.00	0.00	0.00	0.00	5,000.00-	0			
		318.52	318.52	4,681.48	0.00	0.00	318.52-				
			318.52		0.00	5,000.00					
01-900-001-7901	TELEPHONE-OFFICE	0.00	6,000.00	0.00	0.00	6,000.00	0.00	100			
		0.00	713.54	5,286.46	0.00	0.00	5,286.46				
			303.76		0.00	6,000.00					
	Begin Balance: 01/22/26									0.00	
01/26/26 PO 26000021	6 Paid Ck 18536 PHONE & INTERNET - FEB			COMCA005	COMCAST		En 01/16/26 BS	303.76-*	0.00	MARION	
01-900-001-8001	TRUSTEE FEES	0.00	27,000.00	0.00	0.00	27,000.00	18,810.84	30			
		0.00	8,189.16	0.00	0.00	0.00	18,810.84				
			8,189.16		0.00	8,189.16					
	Begin Balance: 01/22/26									27,000.00	
02/02/26 PO 26000129	3 Paid Ck 18538 2010A ARRA ADMIN FEE			USBAN005	U.S. BANK NA		En 02/02/26	5,130.00-	21,870.00	MARION	
02/02/26 PO 26000129	6 Paid Ck 18538 2010A ADMIN FEE			USBAN005	U.S. BANK NA		En 02/02/26	1,725.00-	20,145.00	MARION	
02/02/26 PO 26000129	9 Paid Ck 18538 2025 A-SW1/C-SW1 ADMIN FEE			USBAN005	U.S. BANK NA		En 02/02/26	1,334.16-	18,810.84	MARION	

Account No	Description	Prior Budget Payable YTD	Adopted Expended YTD Expended Curr	Amended Encumber YTD	Transfers Reimbrsd YTD Reimbrsd Curr	Modified Canceled Pd/Chrgd YTD	Balance YTD Unexpended	%Used	Trans Amount	Trans Balance	User
<b>01-900-001-8002 ENGINEERING</b>											
		0.00	54,500.00	0.00	0.00	54,500.00	40,152.76	26			
		14,347.24	14,347.24	0.00	0.00	0.00	40,152.76				
			14,347.24		0.00	14,347.24					
	Begin Balance: 01/22/26									54,500.00	
02/01/26	PO 26000118 1 Rcvd			COLLI005	COLLIERS ENGINEERING & DESIGN	Rc 02/17/26	2,098.64-		52,401.36	MARION	
02/01/26	PO 26000118 2 Rcvd			COLLI005	COLLIERS ENGINEERING & DESIGN	Rc 02/17/26	500.00-		51,901.36	MARION	
02/01/26	PO 26000118 3 Rcvd			COLLI005	COLLIERS ENGINEERING & DESIGN	Rc 02/17/26	5,000.00-		46,901.36	MARION	
02/01/26	PO 26000118 4 Rcvd			COLLI005	COLLIERS ENGINEERING & DESIGN	Rc 02/17/26	6,748.60-		40,152.76	MARION	
<b>01-900-001-8008 LEGAL</b>											
		0.00	50,000.00	0.00	0.00	50,000.00	48,425.00	3			
		1,575.00	1,575.00	0.00	0.00	0.00	48,425.00				
			1,575.00		0.00	1,575.00					
<b>01-900-001-8012 ACCOUNTING</b>											
		0.00	37,500.00	0.00	0.00	37,500.00	37,500.00	0			
		0.00	0.00	0.00	0.00	0.00	37,500.00				
			0.00		0.00	0.00					
<b>01-900-001-8013 PROFESSIONAL-OTHER</b>											
		0.00	6,500.00	0.00	0.00	6,500.00	6,500.00	0			
		0.00	0.00	0.00	0.00	0.00	6,500.00				
			0.00		0.00	0.00					
<b>01-900-001-8101 FRINGE BENEFITS-FICA</b>											
		0.00	165,681.22	0.00	0.00	165,681.22	146,688.58	11			
		0.00	18,992.64	0.00	0.00	0.00	146,688.58				
			11,210.90		0.00	18,992.64					
	Begin Balance: 01/22/26									152,330.06	
01/22/26	PO 26000126 3 Paid Ck 735	FICA EMPLOYER		INTER005	INTERNAL REVENUE SERVICE	En 01/17/26	5,333.03-*		152,330.06	MARION	
01/22/26	PO 26000126 4 Paid Ck 735	FEDERAL UNEMPLOYMENT		INTER005	INTERNAL REVENUE SERVICE	En 01/17/26	236.39-*		152,330.06	MARION	
02/05/26	PO 26000133 3 Paid Ck 737	FICA EMPLOYER		INTER005	INTERNAL REVENUE SERVICE	En 02/05/26	5,641.48-		146,688.58	MARION	
<b>01-900-001-8102 FRINGE BENEFITS-SUI &amp; SDI</b>											
		0.00	16,000.00	0.00	0.00	16,000.00	14,018.20	12			
		0.00	1,981.80	0.00	0.00	0.00	14,018.20				
			1,223.29		0.00	1,981.80					
	Begin Balance: 01/22/26									14,671.95	

Account No	Description	Prior Budget Payable YTD	Adopted Expended YTD Expended Curr	Amended Encumber YTD	Transfers Reimbrsd YTD Reimbrsd Curr	Modified Canceled Pd/Chrgd YTD	Balance YTD Unexpended	%Used	Trans Amount	Trans Balance	User
01-900-001-8102	FRINGE BENEFITS-SUI & SDI										
01/22/26 PO 26000127	3 Paid Ck 736 NJ SUI/SDI EMPLOYER										
02/05/26 PO 26000132	3 Paid Ck 738 NJ SUI/SDI EMPLOYER										
02/05/26 PO 26000133	4 Paid Ck 737 FEDERAL UNEMPLOYMENT										
01-900-001-8103	FRINGE BENEFITS-PERS-PENSION										
		0.00	325,000.00	0.00	0.00	325,000.00	325,000.00	0			
		0.00	0.00	0.00	0.00	0.00	325,000.00				
			0.00		0.00	0.00					
01-900-001-8104	FRINGE BENEFITS-HEALTH PLAN										
		0.00	1,180,540.39	0.00	0.00	1,180,540.39	252,389.96	79			
		25,899.30	148,723.06	779,427.37	0.00	0.00	1,031,817.33				
			56,853.92		0.00	928,150.43					
	Begin Balance: 01/22/26									240,965.74	
01/22/26 Expenditure				Reference	3180	5	6,311.97			247,277.71	MARION
02/05/26 Expenditure				Reference	3181	5	6,222.25			253,499.96	MARION
02/13/26 PO 26000063	1 Rcvd SEMI ANNUAL MEDICARE REIMBURSE			CHARL005	CHARLES	BOYD	Rc 02/17/26		1,110.00-	252,389.96	MARION
02/17/26 PO 26000018	4 Paid Ck 272 ACTIVE EMPLOYEES HEALTH			NJSH0010	NJSHBP		En 01/15/26 BS	43,274.56-*		252,389.96	MARION
02/17/26 PO 26000018	5 Paid Ck 272 RETIRED EMPLOYEES HEALTH			NJSH0010	NJSHBP		En 01/15/26 BS	21,637.28-*		252,389.96	MARION
02/17/26 PO 26000057	1 Paid Ck 271 SEMI ANNUAL MEDICARE REIMBURSE			FRANK005	FRANK	BLAISDELL	En 01/01/26	1,110.00-*		252,389.96	MARION
02/17/26 PO 26000057	1 Void Ck 271 SEMI ANNUAL MEDICARE REIMBURSE			FRANK005	FRANK	BLAISDELL		1,110.00 **		252,389.96	MARION
02/17/26 PO 26000057	1 Rcvd SEMI ANNUAL MEDICARE REIMBURSE			FRANK005	FRANK	BLAISDELL	Rc 01/16/26	1,110.00-*		252,389.96	MARION
	En 01/01/26										
02/17/26 PO 26000057	2 Paid Ck 271 SPOUSE			FRANK005	FRANK	BLAISDELL	En 01/01/26	1,110.00-*		252,389.96	MARION
02/17/26 PO 26000057	2 Void Ck 271 SPOUSE			FRANK005	FRANK	BLAISDELL		1,110.00 **		252,389.96	MARION
02/17/26 PO 26000057	2 Rcvd SPOUSE			FRANK005	FRANK	BLAISDELL	Rc 01/16/26	1,110.00-*		252,389.96	MARION
	En 01/01/26										
01-900-001-8105	FRINGE BENEFITS-DENTAL PLAN										
		0.00	0.00	0.00	0.00	0.00	18,240.00-	0			
		0.00	2,949.13	15,290.87	0.00	0.00	2,949.13-				
			1,435.80		0.00	18,240.00					
	Begin Balance: 01/22/26									18,240.00-	
01/22/26 PO 26000025	3 Paid Ck 18535 DENTAL INSURANCE - FEB			DELTA005	DELTA	DENTAL OF NEW JERSEY,INC	En 01/01/26 BS	1,435.80-*		18,240.00-	MARION

Account No	Description	Prior Budget Payable YTD	Adopted Expended YTD Expended Curr	Amended Encumber YTD	Transfers Reimbrsd YTD Reimbrsd Curr	Modified Canceled Pd/Chrgd YTD	Balance YTD Unexpended	%Used	Trans Amount	Trans Balance	User
01-900-001-8106	FRINGE BENEFITS-GROUP LIFE	0.00	0.00	0.00	0.00	0.00	7,750.00-	0			
		645.18	1,290.36	6,459.64	0.00	0.00	1,290.36-				
			645.18		0.00	7,750.00					
01-900-001-8107	FRINGE BENEFITS-OTHER	0.00	1,500.00	0.00	0.00	1,500.00	1,475.00	2			
		0.00	25.00	0.00	0.00	0.00	1,475.00				
			0.00		0.00	25.00					
01-900-001-8201	PROVISIONS FOR FUTURE BENEFITS	0.00	15,750.00	0.00	0.00	15,750.00	15,750.00	0			
		0.00	0.00	0.00	0.00	0.00	15,750.00				
			0.00		0.00	0.00					
01-900-001-8300	OFFICE EXPENSES	0.00	70,000.00	0.00	0.00	70,000.00	49,045.49	30			
		1,136.27	7,340.41	13,614.10	0.00	0.00	62,659.59				
			7,028.63		0.00	20,954.51					
	Begin Balance: 01/22/26									60,520.00	
01/23/26 PO 26000113	1 Rcvd DOCUMENTS TO D. RILEY			FEDER005	FEDERAL EXPRESS CORP.		Rc 02/12/26	58.15-		60,461.85	NICOLE
01/26/26 PO 26000107	1 Open OFFICE CLEANING 2026 BLANKET			SOUTH005	SOUTH CROSS CLEANING INC		BC	5,000.00-		55,461.85	NICOLE
01/29/26 PO 26000128	1 Paid Ck 18537 ANNUAL BILLING - 2026			POST0015	POSTMASTER- RED BANK		En 01/29/26	5,712.52-		49,749.33	MARION
02/09/26 PO 26000130	1 Paid Ck 18539 EMPLOYEE JOB POSTINGS			INDEE005	INDEED FOR EMPLOYERS		En 02/06/26	179.84-		49,569.49	MARION
02/12/26 PO 26000116	1 Rcvd PO BOX YEARLY RENEWAL			POSTM005	US POSTAL SERVICE		Rc 02/17/26	524.00-		49,045.49	MARION
01-900-001-8401	COMPUTER MAINTENANCE	0.00	0.00	0.00	0.00	0.00	16,330.00-	0			
		0.00	330.00	16,000.00	0.00	0.00	330.00-				
			0.00		0.00	16,330.00					
01-900-001-8500	INSURANCE	0.00	357,061.91	0.00	0.00	357,061.91	137,364.91	62			
		0.00	109,849.00	109,848.00	0.00	0.00	247,212.91				
			0.00		0.00	219,697.00					
01-900-001-8603	EDUCATION, TRAVEL, ENTERTAINMENT	0.00	0.00	0.00	0.00	0.00	885.00-	0			
		0.00	885.00	0.00	0.00	0.00	885.00-				
			0.00		0.00	885.00					

Account No	Description	Prior Budget Payable YTD	Adopted Expended YTD Expended Curr	Amended Encumber YTD	Transfers Reimbrsd YTD Reimbrsd Curr	Modified Canceled Pd/Chrgd YTD	Balance YTD Unexpended	%Used	Trans Amount	Trans Balance	User
01-900-001-8604	ADVERTISING-MEETINGS & BIDS	0.00	0.00	0.00	0.00	0.00	215.56-	0			
		215.56	215.56	0.00	0.00	0.00	215.56-				
			215.56		0.00	215.56					
01-900-001-8605	MISCELLANEOUS	0.00	21,500.00	0.00	0.00	21,500.00	12,358.00	43			
		5.00	6,322.00	2,820.00	0.00	0.00	15,178.00				
			525.00		0.00	9,142.00					
	Begin Balance: 01/22/26									12,403.00	
01/22/26 PO 26000029	2 Paid Ck 18534 EZ PASS			EZPAS010	EZ PASS		En 01/02/26 BS		240.00-*	12,403.00	MARION
02/12/26 PO 26000029	3 Paid Ck 18541 EZ PASS			EZPAS010	EZ PASS		En 01/02/26 BS		240.00-*	12,403.00	MARION
02/12/26 PO 26000119	1 Paid Ck 18540 BACKGROUND CHECK - B.LILIENKAMP			DIVIS005	DIVISION OF STATE POLICE-SBIS		En 02/12/26		20.00-	12,383.00	MARION
02/12/26 PO 26000119	2 Paid Ck 18540 BACKGROUND CHECK - K.MCNELIS			DIVIS005	DIVISION OF STATE POLICE-SBIS		En 02/12/26		20.00-	12,363.00	MARION
02/13/26 PO 26000074	1 Rcvd FILING FEE - MR.RILEY			TREA0015	TREASURER STATE OF N.J.		Rc 02/17/26		5.00-	12,358.00	MARION
Control: 001	Total	0.00	4,427,677.35	0.00	0.00	4,427,677.35	2,830,649.89	36			
		44,142.07	643,499.54	953,527.92	0.00	0.00	3,784,177.81				
			389,536.92		0.00	1,597,027.46					
01-900-002-0000	COLLECTION										
01-900-002-5001	MAINTENANCE LABOR-COLLECTION	0.00	435,824.75	0.00	0.00	435,824.75	402,946.41	8			
		0.00	32,878.34	0.00	0.00	0.00	402,946.41				
			21,796.46		0.00	32,878.34					
	Begin Balance: 01/22/26									424,742.87	
01/22/26 Expenditure				Reference	3180 3		10,382.18-			414,360.69	MARION
02/05/26 Expenditure				Reference	3181 2		11,414.28-			402,946.41	MARION
01-900-002-7101	REPAIRS & SUPPLIES-COLLECTION	0.00	53,500.00	0.00	0.00	53,500.00	9,785.00-	118			
		1,583.89	1,583.89	61,701.11	0.00	0.00	51,916.11				
			1,583.89		0.00	63,285.00					
01-900-002-7401	AUTO, TRUCK-REPAIR, PARTS-COLL.	0.00	26,200.00	0.00	0.00	26,200.00	24,800.00	5			
		0.00	0.00	1,400.00	0.00	0.00	26,200.00				
			0.00		0.00	1,400.00					

Account No	Description	Prior Budget Payable YTD	Adopted Expended YTD Expended Curr	Amended Encumber YTD	Transfers Reimbrsd YTD Reimbrsd Curr	Modified Canceled Pd/Chrgd YTD	Balance YTD Unexpended	%Used	Trans Amount	Trans Balance	User
01-900-002-7402	AUTO,TRUCK-GASOLINE-COLL.	0.00	0.00	0.00	0.00	0.00	5,000.00-	0			
		318.52	318.52	4,681.48	0.00	0.00	318.52-				
			318.52		0.00	5,000.00					
Control: 002	Total	0.00	515,524.75	0.00	0.00	515,524.75	412,961.41	20			
		1,902.41	34,780.75	67,782.59	0.00	0.00	480,744.00				
			23,698.87		0.00	102,563.34					
01-900-003-0000	DISPOSAL										
01-900-003-5001	OPERATING LABOR-DISPOSAL	0.00	1,449,162.41	0.00	0.00	1,449,162.41	1,302,500.94	10			
		0.00	146,661.47	0.00	0.00	0.00	1,302,500.94				
			90,395.36		0.00	146,661.47					
	Begin Balance: 01/22/26									1,392,896.30	
	01/22/26 Expenditure			Reference	3180	4	43,742.40-			1,349,153.90	MARION
	02/05/26 Expenditure			Reference	3181	4	46,652.96-			1,302,500.94	MARION
01-900-003-7101	REPAIRS AND SUPPLIES-DISPOSAL	0.00	215,000.00	0.00	0.00	215,000.00	49,482.49	77			
		42,979.91	43,669.89	121,847.62	0.00	0.00	171,330.11				
			42,979.91		0.00	165,517.51					
	Begin Balance: 01/22/26									51,323.57	
	01/23/26 PO 26000112	2	Rcvd	ICE MELT	HOMED005	HOME DEPOT CREDIT SERVICES	Rc 02/12/26		1,006.11-	50,317.46	NICOLE
	01/27/26 PO 26000122	1	Rcvd	FIRE EXTINGUISHER SERVICE	ALLI0010	ALLIED FIRE & SAFETY EQUIP	INC Rc 02/13/26		735.00-	49,582.46	NICOLE
	02/12/26 PO 26000112	1	Rcvd	SPREADER	HOMED005	HOME DEPOT CREDIT SERVICES	Rc 02/12/26		99.97-	49,482.49	NICOLE
01-900-003-7102	REPAIRS & SUPPLIES - LAB	0.00	0.00	0.00	0.00	0.00	45,925.00-	0			
		1,464.88	1,464.88	44,460.12	0.00	0.00	1,464.88-				
			1,464.88		0.00	45,925.00					
01-900-003-7300	GRIT REMOVAL	0.00	31,200.00	0.00	0.00	31,200.00	0.00	100			
		3,696.00	3,696.00	27,504.00	0.00	0.00	27,504.00				
			3,696.00		0.00	31,200.00					
	Begin Balance: 01/22/26									31,200.00	
	01/22/26 PO 26000005	2	Open	GRIT - BLANKET	FREEH005	FREEHOLD CARTAGE INC	BC		27,504.00-	3,696.00	NICOLE

Account No	Description	Prior Budget Payable YTD	Adopted Expended YTD Expended Curr	Amended Encumber YTD	Transfers Reimbrsd YTD Reimbrsd Curr	Modified Canceled Pd/Chrgd YTD	Balance YTD Unexpended	%Used	Trans Amount	Trans Balance	User
01-900-003-7300	GRIT REMOVAL										
	Continued										
01/22/26 PO 26000005	3 Rcvd				FREEH005	FREEHOLD CARTAGE INC	Rc 02/13/26 BS		1,848.00-	1,848.00	NICOLE
01/22/26 PO 26000005	4 Rcvd				FREEH005	FREEHOLD CARTAGE INC	Rc 02/13/26 BS		1,848.00-	0.00	NICOLE
01-900-003-7301	SLUDGE REMOVAL EXPENSES										
		0.00	819,642.49	0.00	0.00	819,642.49	0.00	100			
		0.00	0.00	819,642.49	0.00	0.00	819,642.49				
			0.00		0.00	819,642.49					
	Begin Balance: 01/22/26									819,642.49	
01/22/26 PO 26000005	1 Open				FREEH005	FREEHOLD CARTAGE INC	BC		819,642.49-	0.00	MARION
01-900-003-7302	NJ-PERMIT & REGISTRATION FEES										
		0.00	80,000.00	0.00	0.00	80,000.00	77,820.00	3			
		2,180.00	2,180.00	0.00	0.00	0.00	77,820.00				
			2,180.00		0.00	2,180.00					
	Begin Balance: 01/22/26									80,000.00	
02/12/26 PO 26000117	1 Rcvd				TREAS005	TREASURER-STATE OF N.J.	Rc 02/17/26		1,090.00-	78,910.00	MARION
02/12/26 PO 26000117	2 Rcvd				TREAS005	TREASURER-STATE OF N.J.	Rc 02/17/26		1,090.00-	77,820.00	MARION
01-900-003-7401	AUTO, TRUCK-REPAIR/PARTS-DISP.										
		0.00	17,500.00	0.00	0.00	17,500.00	16,100.00	8			
		0.00	0.00	1,400.00	0.00	0.00	17,500.00				
			0.00		0.00	1,400.00					
01-900-003-7402	AUTO, TRUCK-GASOLINE-DISP.										
		0.00	0.00	0.00	0.00	0.00	10,000.00-	0			
		637.04	637.04	9,362.96	0.00	0.00	637.04-				
			637.04		0.00	10,000.00					
01-900-003-7501	CHEMICALS										
		0.00	449,750.00	0.00	0.00	449,750.00	449,750.00	0			
		0.00	0.00	0.00	0.00	0.00	449,750.00				
			0.00		0.00	0.00					
01-900-003-7503	CHEMICALS-POLYMER										
		0.00	0.00	0.00	0.00	0.00	115,000.00-	0			
		7,406.00	7,406.00	107,594.00	0.00	0.00	7,406.00-				
			7,406.00		0.00	115,000.00					

Account No	Description	Prior Budget Payable YTD	Adopted Expended YTD Expended Curr	Amended Encumber YTD	Transfers Reimbrsd YTD Reimbrsd Curr	Modified Canceled Pd/Chrgd YTD	Balance YTD Unexpended	%Used	Trans Amount	Trans Balance	User
01-900-003-7504	CHEMICALS-SODIUM HYPOCHLORITE	0.00	0.00	0.00	0.00	0.00	165,000.00-	0			
		9,696.10	9,696.10	155,303.90	0.00	0.00	9,696.10-				
			9,696.10		0.00	165,000.00					
01-900-003-7505	CHEMICALS-OTHER	0.00	0.00	0.00	0.00	0.00	2,000.00-	0			
		0.00	0.00	2,000.00	0.00	0.00	0.00				
			0.00		0.00	2,000.00					
01-900-003-7506	CHEMICALS-MAGNESIUM HYDROXIDE	0.00	0.00	0.00	0.00	0.00	75,000.00-	0			
		0.00	0.00	75,000.00	0.00	0.00	0.00				
			0.00		0.00	75,000.00					
01-900-003-7507	CHEMICAL-ALUMINUM HYDROXIDE	0.00	0.00	0.00	0.00	0.00	35,000.00-	0			
		2,632.38	2,632.38	32,367.62	0.00	0.00	2,632.38-				
			2,632.38		0.00	35,000.00					
01-900-003-7602	HEAT-GAS	0.00	120,000.00	0.00	0.00	120,000.00	0.00	100			
		13,024.02	13,024.02	106,975.98	0.00	0.00	106,975.98				
			13,024.02		0.00	120,000.00					
01-900-003-7701	ELECTRIC-DISPOSAL	0.00	367,500.00	0.00	0.00	367,500.00	7,500.00	98			
		28,726.37	28,726.37	331,273.63	0.00	0.00	338,773.63				
			28,726.37		0.00	360,000.00					
	Begin Balance: 01/22/26									367,500.00	
02/12/26 PO 26000022	1 Open			JCPLC005	J.C.P.& L CO.				BC	331,273.63-	36,226.37
02/12/26 PO 26000022	3 Rcvd			JCPLC005	J.C.P.& L CO.				Rc 02/13/26 BS	28,726.37-	7,500.00
01-900-003-7801	WATER - PLANT - JOLINE AVENUE	0.00	16,840.00	0.00	0.00	16,840.00	40.00	100			
		1,411.47	1,411.47	15,388.53	0.00	0.00	15,428.53				
			1,411.47		0.00	16,800.00					
01-900-003-7901	TELEPHONE-DISPOSAL	0.00	6,000.00	0.00	0.00	6,000.00	688.00	89			
		0.00	613.55	4,698.45	0.00	0.00	5,386.45				
			312.78		0.00	5,312.00					

Account No	Description	Prior Budget Payable YTD	Adopted Expended YTD Expended Curr	Amended Encumber YTD	Transfers Reimbrsd YTD Reimbrsd Curr	Modified Canceled Pd/Chrgd YTD	Balance YTD Unexpended	%Used	Trans Amount	Trans Balance	User
01-900-003-7901	TELEPHONE-DISPOSAL										
	Continued										
	Begin Balance: 01/22/26									688.00	
01/26/26 PO 26000021	5 Paid Ck 18536 PHONE & INTERNET - FEB				COMCA005 COMCAST		En 01/16/26 BS		312.78-*	688.00	MARION
Control: 003	Total	0.00	3,572,594.90	0.00	0.00	3,572,594.90	1,455,956.43	59			
		113,854.17	261,819.17	1,854,819.30	0.00	0.00	3,310,775.73				
			204,562.31		0.00	2,116,638.47					
01-900-004-0000	PUMP STATIONS										
01-900-004-7101	REPAIRS AND SUPPLIES-PUMPING										
		0.00	37,500.00	0.00	0.00	37,500.00	17,300.00	54			
		471.19	471.19	19,728.81	0.00	0.00	37,028.81				
			471.19		0.00	20,200.00					
	Begin Balance: 01/22/26									17,300.00	
02/13/26 PO 26000022	2 Deleted ELECTRIC - BLANKET				JCPLC005 J.C.P.& L CO.		En 02/12/26 BC		22,300.00 **	17,300.00	MARION
01-900-004-7701	ELECTRIC-PUMP STATIONS										
		0.00	30,975.00	0.00	0.00	30,975.00	975.00	97			
		3,281.55	3,281.55	26,718.45	0.00	0.00	27,693.45				
			3,281.55		0.00	30,000.00					
	Begin Balance: 01/22/26									30,975.00	
02/13/26 PO 26000022	4 Rcvd EXCHANGE PL PS				JCPLC005 J.C.P.& L CO.		Rc 02/13/26 BS		63.14-	30,911.86	MARION
02/13/26 PO 26000022	5 Open ELECTRIC - BLANKET				JCPLC005 J.C.P.& L CO.		BC		26,718.45-	4,193.41	MARION
02/13/26 PO 26000022	6 Rcvd MONMOUTH PL PS				JCPLC005 J.C.P.& L CO.		Rc 02/13/26 BS		76.20-	4,117.21	MARION
02/13/26 PO 26000022	7 Rcvd HOEY & OVERLOOK AVE PS				JCPLC005 J.C.P.& L CO.		Rc 02/13/26 BS		1,035.52-	3,081.69	MARION
02/13/26 PO 26000022	8 Rcvd LINCOLN AVE & OCEAN AVE PS				JCPLC005 J.C.P.& L CO.		Rc 02/13/26 BS		257.07-	2,824.62	MARION
02/13/26 PO 26000022	9 Rcvd MCCLELLAN ST PS				JCPLC005 J.C.P.& L CO.		Rc 02/13/26 BS		229.85-	2,594.77	MARION
02/13/26 PO 26000022	10 Rcvd JOLINE AVE PS				JCPLC005 J.C.P.& L CO.		Rc 02/13/26 BS		1,619.77-	975.00	MARION
Control: 004	Total	0.00	68,475.00	0.00	0.00	68,475.00	18,275.00	73			
		3,752.74	3,752.74	46,447.26	0.00	0.00	64,722.26				
			3,752.74		0.00	50,200.00					

Account No	Description	Prior Budget Payable YTD	Adopted Expended YTD Expended Curr	Amended Encumber YTD	Transfers Reimbrsd YTD Reimbrsd Curr	Modified Canceled Pd/Chrgd YTD	Balance YTD Unexpended	%Used	Trans Amount	Trans Balance	User
01-900-004-7801	WATER										
01-900-004-7802	WATER- PUMP STATIONS										
		0.00	2,000.00	0.00	0.00	2,000.00	0.00	100			
		142.97	142.97	1,857.03	0.00	0.00	1,857.03				
			142.97		0.00	2,000.00					
Control: 004	Total	0.00	2,000.00	0.00	0.00	2,000.00	0.00	100			
		142.97	142.97	1,857.03	0.00	0.00	1,857.03				
			142.97		0.00	2,000.00					
01-900-005-0000	CAPITAL										
01-900-005-9003	VEHICLES										
		0.00	30,000.00	0.00	0.00	30,000.00	30,000.00	0			
		0.00	0.00	0.00	0.00	0.00	30,000.00				
			0.00		0.00	0.00					
01-900-005-9005	TREATMENT PLANT EQUIPMENT										
		0.00	60,000.00	0.00	0.00	60,000.00	60,000.00	0			
		0.00	0.00	0.00	0.00	0.00	60,000.00				
			0.00		0.00	0.00					
01-900-005-9006	ROOF REPLACEMENT										
		0.00	20,000.00	0.00	0.00	20,000.00	20,000.00	0			
		0.00	0.00	0.00	0.00	0.00	20,000.00				
			0.00		0.00	0.00					
01-900-005-9007	SECONDARY TREATMENT PLANT										
		0.00	30,000.00	0.00	0.00	30,000.00	30,000.00	0			
		0.00	0.00	0.00	0.00	0.00	30,000.00				
			0.00		0.00	0.00					
01-900-005-9008	DIGESTER CLEANING/COVERS										
		0.00	65,000.00	0.00	0.00	65,000.00	65,000.00	0			
		0.00	0.00	0.00	0.00	0.00	65,000.00				
			0.00		0.00	0.00					
01-900-005-9009	JET VAC TRUCK										
		0.00	55,000.00	0.00	0.00	55,000.00	55,000.00	0			
		0.00	0.00	0.00	0.00	0.00	55,000.00				
			0.00		0.00	0.00					

Account No	Description	Prior Budget Payable YTD	Adopted Expended YTD Expended Curr	Amended Encumber YTD	Transfers Reimbrsd YTD Reimbrsd Curr	Modified Canceled Pd/Chrgd YTD	Balance YTD Unexpended	%Used	
Date	Transaction Data/Comment				Vendor/Reference			Trans Amount	Trans Balance User
01-900-005-9011	COLLECTION SYSTEM IMPROVEMENTS	0.00	22,500.00	0.00	0.00	22,500.00	22,500.00	0	
		0.00	0.00	0.00	0.00	0.00	22,500.00		
			0.00		0.00	0.00			
01-900-005-9012	PUMP STATION EQUIPMENT	0.00	30,000.00	0.00	0.00	30,000.00	30,000.00	0	
		0.00	0.00	0.00	0.00	0.00	30,000.00		
			0.00		0.00	0.00			
Control: 005	Total	0.00	312,500.00	0.00	0.00	312,500.00	312,500.00	0	
		0.00	0.00	0.00	0.00	0.00	312,500.00		
			0.00		0.00	0.00			
Fund: 01	Budgeted Total	0.00	8,898,772.00	0.00	0.00	8,898,772.00	5,030,342.73	43	
		163,794.36	943,995.17	2,924,434.10	0.00	0.00	7,954,776.83		
			621,693.81		0.00	3,868,429.27			
Fund: 01	Non-Budgeted Total	0.00	0.00	0.00	0.00	0.00	0.00	0	
		0.00	0.00	0.00	0.00	0.00	0.00		
			0.00		0.00	0.00			
Fund: 01	Total	0.00	8,898,772.00	0.00	0.00	8,898,772.00	5,030,342.73	43	
		163,794.36	943,995.17	2,924,434.10	0.00	0.00	7,954,776.83		
			621,693.81		0.00	3,868,429.27			
Final Budgeted		0.00	8,898,772.00	0.00	0.00	8,898,772.00	5,030,342.73	43	
		163,794.36	943,995.17	2,924,434.10	0.00	0.00	7,954,776.83		
			621,693.81		0.00	3,868,429.27			
Final Non-Budgeted		0.00	0.00	0.00	0.00	0.00	0.00	0	
		0.00	0.00	0.00	0.00	0.00	0.00		
			0.00		0.00	0.00			
Final Total		0.00	8,898,772.00	0.00	0.00	8,898,772.00	5,030,342.73	43	
		163,794.36	943,995.17	2,924,434.10	0.00	0.00	7,954,776.83		
			621,693.81		0.00	3,868,429.27			

**LONG BRANCH SEWERAGE AUTHORITY**  
**MINUTES OF THE REGULAR MEETING**  
**JANUARY 21, 2026**

**I. and II. Opening and Attendance at Meeting and Pledge of Allegiance**

A Regular Meeting of the Long Branch Sewerage Authority was called to order at 3:00 p.m., prevailing time, on Wednesday, January 21, 2026, by the Executive Director, Thomas Roguski, both in person and electronically via telecommunication conference, attended by Mr. Riley, Mr. Booth, Mr. Larco, and Mr. Brown. Mrs. Morris arrived at 3:02 p.m.

In addition to the Members of the Authority hereinabove stated, there were present at said Regular Meeting the following professional attaches: Thomas Roguski, P.E., Executive Director; John L. Bonello, Esq., of the firm Manna & Bonello, P.A., Authority Counsel; John McKelvey P.E., of the firm Colliers Engineering and Design, Authority Engineer; Charles J. Fallon, CPA, RMA, of the firm Fallon & Company LLP, Authority Auditor; and Susan Mazzei, Secretary.

**III. Announcement Pursuant to New Jersey Open Public Meeting Act.**

Adequate Notice of this Regular Meeting and of all Regular Meetings for the Year 2025, has been provided by publication thereof in the *Link News* on February 24, 2025 as a “legal” advertisement, in the *Asbury Park Press* on February 26, 2025 as a “legal” advertisement and in the *Coaster* on February 27, 2025 as a “legal” advertisement, and by forwarding duplicates thereof on February 20, 2025, to the Clerks of the City of Long Branch, Borough of West Long Branch and Borough of Monmouth Beach for filing in their respective offices and for posting in a public place in each such Municipality.

**IV. Public Participation.**

Mr. Vincent Lepore from 33 Ocean Terrace was present via telephonic communication.

Mr. Lepore spoke regarding Correspondence Item No. 8, Transit Village Medical District, and stated it was tabled at the City and State level.

Mr. Lepore referenced Correspondence Item No. 9 and Correspondence Item No. 10, Affidavits of Publication, and asked if the Authority had the online bidding of professionals posted the website in accordance to the new law.

Mr. Roguski stated affirmatively and added that the new law goes into effect on 3/1/2026. The Authority has been proactive and has already posted the Public Notices and the Notice of Professionals on the website.

Mr. Lepore thanked Mr. Roguski for doing that in advance.

Mr. Lepore inquired about the replacement of Rt. 36 Bridge and asked if an appraisal was carried out and questioned why the Authority hired an Environmental Attorney, Mr. David Isabel, for the sale of the easements as it seems so straight forward as to not use our General Counsel, John Bonello.

Mr. Roguski stated that the agreement of sale for \$3,800.00 was based on an appraisal. Mr. Roguski also stated that it was necessary to retain Mr. Isabel to ensure the Authority is protected from an environmental perspective, as the agreement of sale included several environmental provisions.

Mr. Lepore compared the car dealership and the land that was sold on Broadway years ago to the agreement of sale of the easement for the Rt.36 Bridge Project.

Mr. Roguski explained the sale was different; the car dealership and land sale was a quick claim deed and the buyer held the Authority harmless and took responsibility. The Rt 36 Bridge Project and sale of the easement is dealing with the DEP and that arrangement would not be permissible.

Mr. Lepore then questioned the increase in insurance benefits for employees and asked what budget the money will be coming out to pay for the difference. Mr. Roguski said it will be coming out of line item for healthcare.

Mr. Lepore asked if there will be any New Business on the Agenda, and Mr. Roguski stated he had nothing currently planned.

Mr. Lepore thanked Mr. Roguski and the Board.

On Motion by Mr. Booth, seconded by Mr. Brown, and passed by the affirmative vote of all members present, no nays, no absent, no abstain; the Public Participation portion of the Meeting was closed.

## **V. Miscellaneous Suggestions for the Good of the Authority**

Mr. Vincent Lepore from 33 Ocean Terrace was present via telephonic communication.

Mr. Lepore had a question about the future of the NJ Environmental Trust Fund. Mr. Lepore asked about State funding. Mr. Roguski replied that the State advised that funding is unaffected going into the next funding cycle, though no information is available for subsequent cycles.

Mr. Lepore questioned what rate the Authority is paying for gas and water, and where the Authority stands in terms of rates.

Mr. Roguski said the Authority is on market rates for gas and stated that, based upon

analysis with the Authority's consultant, it previously did not make sense to lock into rates with natural gas because the price is low. As far as water is concerned, Mr. Roguski wasn't sure if that is even an option with NJAW.

Mr. Lepore thanked Mr. Roguski and the Board

On Motion by Mr. Booth, seconded by Mr. Brown, and passed by the affirmative vote of all members present, no nays, no absent, no abstain; the Miscellaneous Suggestions for the Good of the Authority portion of the Meeting was closed.

**VI. As to the Minutes of the Regular Meeting of December 17, 2025**

On Motion by Mr. Booth, seconded by Mr. Brown, and passed by the affirmative vote of four (4) members, no nays, no absent, one abstain (Mr. Larco), the reading of the Minutes of the Regular Meeting of the Long Branch Sewerage Authority held on December 17, 2025, to be dispensed with and that such Minutes be, and they are hereby, approved as recorded and circulated.

**VII. As to the Minutes of the Executive Session held on December 17, 2025, if any**

None

**VIII. Correspondence**

The attached list of correspondence was reviewed by the Authority. Individual items were dealt with as follows:

Mr. Roguski reported Correspondence Item No. 11 is a letter from Colliers Engineering and Design recommending approval of Partial Payment No.1 to Rapid Pump & Meter Service & Co. for the Hoey Pump Station Improvements Project in the amount of \$ 171,892.00.

The following resolution was presented.

**RESOLUTION**

Mr. Brown offered the following Resolution and moved its adoption; seconded by Mr. Booth

**WHEREAS**, the Long Branch Sewerage Authority has received Partial Payment Request No. 1 from Rapid Pump & Meter Service Co. for the Hoey Pump Station Improvements Project, and

**WHEREAS**, this request for payment is in the amount of

\$171,892.00, and

**WHEREAS**, the Authority Engineer, Colliers Engineering & Design, has recommended approval of this request, per their letter dated January 14, 2026, attached hereto and made a part hereof.

**NOW, THEREFORE, BE IT RESOLVED** by the Long Branch Sewerage Authority that it approves payment of Partial Payment Request No.1 to Rapid Pump & Meter Service Co. in the amount of \$171,892.00, and

**BE IT FURTHER RESOLVED** that the Authority Chairman and/or Executive Director are authorized to sign any documents necessary to effectuate this resolution.

ROLL CALL:

Mr. Riley	- AYE
Mr. Booth	- AYE
Mr. Brown	- AYE
Mr. Larco	- AYE
Mrs. Morris	- AYE

Date: January 21, 2026  
R1.1-26  
Exhibit A

\*\*\*\*

Mr. Roguski had nothing further to report under Correspondence.

**LIST OF CORRESPONDENCE FOR REGULAR MEETING  
LONG BRANCH SEWERAGE AUTHORITY  
JANUARY 21, 2026**

1. Copy of a letter dated 12/19/25 received 12/19/25 from Colliers Engineering and Design to Dynamic Engineering Consultants, PC, re: North Light, LLC/Project No.LBS-0353/ 305 Broadway/ Block 268 Lot 1-7, 32 & 33
2. Copy of letter dated 12/19/25 received 12/19/25 from Colliers Engineering & Design to Ian Holdings, LLC, re: 85 Chelsea Ave/Project No.LBS-0351/ Block 287.01 Lot 21

3. Copy of letter dated 12/19/25 received 12/19/25 from Colliers Engineering & Design to Gio Associates, LLC, re: 83 North Broadway/Project No. LBS-0357/Block 305 Lot 9
4. Affidavit of Publication dated 12/29/25 received 12/29/25 from Asbury Park Press, re: Synopsis of the 2024 Audit.
5. Certified Notice of Hearing for Borough of West Long Branch dated 1/7/26 received 1/12/26 from Ansell Grimm & Aaron, PC, re: Block 67/Lot8.03 Borough of West Long Branch (**NOT LBSA**)
6. Certified Notice of Hearing dated 11/11/25 from Paul R. Edinger, Esq. received 1/12/26, re:135 Morris, LLC/ 125, 133 & 141 Morris Ave /Block 229/ Lots 21, 22 & 23
7. Certified Notice of Hearing received 1/12/26 from Monmouth University, re: 400 Cedar Avenue / Block 39 Lots 1, 2, 3, 4, 5, 7, 8, 9, 11,12.01 and 12.02 / West Long Branch
8. Certified Letter dated 11/26/26 and received 1/12/26 from Long Branch City Clerk, re: Ordinance 0-20-25; amending specific zoning for Transit Village District/Medical Village Sub District
9. Affidavit of Publication dated 1/8/26 received 1/12/26 from the Asbury Park Press/ Notice to Bidders/ request for Professional Proposals
10. Affidavit of Publication dated 1/14/26 received 1/15/26 from the Asbury Park Press/ Official Internet Website for Public Notice
11. Copy of letter dated 1/14/26 received 1/15/26 from Colliers Engineering & Design, re: Partial Payment No.1 to Rapid Pump & Meter Service & Co. for Hoey Pump Station Improvement Project No. LBS-0330
12. Letter dated 1/14/26 received 1/15/26 from John J. McKelvey, re: Engineer's Status Report
13. Certified Notice of Public Hearing received 1/16/26 from Rosario Realty, re:317 Norwood Ave/ Block 105/Lot 17
14. Certified Notice of Public Hearing received 1/16/26 from Rosario Realty, re 657 Campbell Ave/ Block 166 /Lot 1

**ACTION**

On Motion by Mr. Booth, seconded by Mr. Brown and passed by the affirmative vote of all members present, no nays, no absent, no abstain, the attached List of Correspondence was ordered, received, and filed.

## **IX. Report of Executive Director for the January 2026 Authority Meeting**

Mr. Roguski reported that the Authority treated an average daily flow of 2.19 MGD and has met all limits of our discharge permit.

Mr. Roguski stated that the Authority advertised Request for Proposals for Professional Services, with proposal openings scheduled for February 5, 2026. Proposals will then be evaluated and recommendations to the Board regarding professional appointments at the February 2026 meeting.

Mr. Roguski presented a resolution for the Agreement of Sale of a permanent easement to the DOT for \$3,800.00. The Agreement is to facilitate the State's proposed improvements to replace the Route 36 Bridge over Troutman's Creek. Mr. Roguski stated that the land is still owned by Authority.

The following resolution was presented.

### **RESOLUTION**

Mr. Booth offered the following Resolution and moved its adoption; seconded by Mr. Brown

**WHEREAS**, the State of New Jersey, hereinafter referred to as the "State," is undertaking the replacement of the bridge along Route 36 over Troutman's Creek immediately adjacent to the Authority's Administrative Building located in the City of Long Branch, Monmouth County, hereinafter referred to as the "Project," and

**WHEREAS**, the Project requires a permanent easement and two (2) temporary easements on property owned by the Long Branch Sewerage Authority, hereinafter referred to as the "Authority," and

**WHEREAS**, the State, in pursuance of the Project, has requested the Authority to execute an Agreement of Sale, attached hereto and made a part hereof, hereinafter referred to as the "Agreement," and

**WHEREAS**, the Authority Environmental Attorney reviewed the Agreement and noted no objections to the Authority entering into the Agreement, and

**WHEREAS**, the Authority believes that entering into the Agreement to facilitate the State's proposed improvements to replace the Route 36 Bridge over Troutman's Creek is in the best interest of the City of Long Branch and the Long Branch Sewerage Authority.

**NOW, THEREFORE, BE IT RESOLVED**, by the Long Branch Sewerage Authority that

1. The Authority hereby agrees to the terms and conditions of the referenced Agreement.
2. The Authority will sell for the sum of \$3,800.00 to the State of New Jersey, all that certain parcels known as parcels E89A, E89B, and E89C owned by Long Branch Sewerage Authority of Long Branch, as per the terms of the Agreement of Sale, attached hereto and made a part hereof, between the parties.
3. The Authority Chairman, Donald S. Riley, the Authority Secretary, David G. Brown, and/or the Authority Executive Director, Thomas Roguski, are authorized to sign the referenced Agreement, any documents needed to effectuate this resolution and associated with the referenced Agreement, and any instruments necessary in connection with the referenced Agreement.

ROLL CALL:

Mr. Riley	- AYE
Mr. Booth	- AYE
Mr. Brown	- AYE
Mr. Larco	- AYE
Mrs. Morris	- AYE

Date: January 21, 2026

R2.1-26

Exhibit B

CERTIFICATION

I, \_\_\_\_\_, Chairman of the Long Branch Sewerage Authority, do hereby certify that at a meeting of the Long Branch Sewerage Authority of Long Branch, New Jersey, the Commissioners of the Long Branch Sewerage Authority, duly called and held at its principal office, 150 Joline Avenue, Long Branch, NJ 07740, on this 21<sup>st</sup> day of January 2026, at which a quorum was present, the foregoing resolution was adopted.

Long Branch Sewerage Authority:

---

Donald S. Riley, Chairman

---

Date

Mr. Roguski had nothing further to report.

On Motion by Mr. Booth seconded by Mr. Riley and passed by the affirmative vote of all members present, no nays, no absent, no abstain, the report of the Executive Director, as prepared and submitted, is hereby approved, and ordered, received and filed and made part of the Minutes of this Meeting.

**X. Report by Authority Counsel of the Activities of that Office and of Actions taken since December 17, 2025**

Mr. Bonello said it was another quiet month. Mr. Bonello had nothing to report.

On Motion by Mr. Brown, seconded by Mr. Booth and passed by the affirmative vote of all members present, no nays, no absent, no abstain, all actions taken, and dispositions made by the Authority Counsel of and with regard to each and all of the foregoing items be, and they are in all respects approved, confirmed, and ratified.

**XI. Report by Authority Auditor of the Activities of that Office and of Actions taken since December 17, 2025**

Mr. Fallon said he had nothing to report.

On Motion by Mr. Booth, seconded by Mr. Brown and passed by the affirmative vote of all members present, no nays, no absent, no abstain, all actions taken, and dispositions made by Authority Auditor of and with regard to each and all of the foregoing items be, and they are in all respects, approved, confirmed and ratified.

**XII. Report by Authority Consulting Engineer of the Activities of that Office and of Actions taken December 17, 2025**

Mr. McKelvey reported on the Hoey Pump Station Project and stated that there will be a few more submissions as far as construction of the minor changes to the elevated platform.

Colliers is currently reviewing a change order request from Rapid Pump and Meter Service Co. and anticipates having that change order for Authority and DEP approval in a few weeks. Mr. McKelvey confirmed that construction is still slated for spring and pay requests have been approved.

Mr. McKelvey stated there was minimal construction on the development end and there were no new applications.

Mr. McKelvey had nothing further to report.

On Motion by Mr. Brown, seconded by Mr. Booth, and passed by the affirmative vote of all members present, no nays, no absent, no abstain, all actions taken, and dispositions made by Authority Consulting Engineer of and with regard to each and all of the foregoing items be, and they are in all respects, approved, confirmed and ratified.

**XIII. Transfers, if any.**

The transfers are as listed.

The following Resolution was moved by Mr. Brown, seconded by Mr. Booth and passed by the affirmative vote of all members present, no nays, no absent, no abstain, approving the Authority Transfers for the month of December 2025 as listed.

**RESOLUTION**

BE IT RESOLVED BY THE LONG BRANCH SEWERAGE AUTHORITY IN SESSION AT A REGULAR MEETING THEREOF ON THIS 21st DAY OF JANUARY 2026 PURSUANT TO NOTICE AT WHICH AT LEAST A QUORUM IS PRESENT that the Authority hereby approves the Transfers made for the month of December 2025 as submitted by the Executive Director and orders said report received and filed.

**XIV. As to Bills submitted for payment by Long Branch Sewerage Authority for the January 21, 2026 Meeting**

The following Resolution was moved by Mr. Booth, seconded by Mr. Riley, and passed by the affirmative vote of all members present, no nays, no absent, no abstain.

**RESOLUTION**

BE IT RESOLVED BY THE LONG BRANCH SEWERAGE AUTHORITY IN SESSION AT A REGULAR MEETING THEREOF ON THIS 21st DAY OF JANUARY 2026 PURSUANT TO NOTICE AT WHICH AT LEAST A QUORUM IS PRESENT, the List of Bills for the month of December 2025 are found regular and payment of each and all, thereof is authorized to be paid out of the Revolving Fund, General Funds, Revenue Fund or Collection Account as indicated on the said List of Bills attached to the Executive Director's Report.

**XV. Report, if any, by Investment Committee.**

No report from the investment committee.

**XVI. Old Business**

No old business.

**XVII. New Business**

No new business.

**XVIII. Adjournment at 3:19 p.m.**

There being no further business, on Motion by Mr. Booth, seconded by Mr. Brown and passed by the affirmative vote of all members present, no nays, no absent, no abstain, the meeting was adjourned at 3:19 p.m.

Respectfully submitted,

---

David G. Brown, Secretary

---

Thomas Roguski, Executive Director

RECEIVED

JAN 20 2026  
Certified  
L.B. CLERK AUTH

BOROUGH OF WEST LONG BRANCH

PLANNING BOARD  ZONING BOARD

PLEASE TAKE NOTICE that on the 17th day of March 2026, at 7:00 at the Municipal Building, 965 Broadway, West Long Branch, New Jersey, a Public Hearing will be held before the West Long Branch Planning and Zoning Board to consider the application of Krysta Gleeson Parker and Eric Parker residing at 110 Wall Street designated as Block 25, Lot(s) 7 on the official tax map (Block) 25 (Lot Numbers) 7 of the Borough of West Long Branch, Zone District R-15, at which time and place all interested persons will be given an opportunity to be heard.

The applicant seeks the following: A second floor addition not expanding on existing structural footprint and a side yard variance (18-5.1)

The applicant also seeks any and all other variances or waivers as may be required in connection of this application.

The application and supporting documents are on file at the Office of the West Long Branch Borough Clerk, 965 Broadway, West Long Branch, New Jersey, and available for inspection by the public during regular business hours (8:30 a.m. to 4:30 p.m.).

This notice is sent to you as an owner of property in the immediate vicinity of this application and is also published, as required by law. Any interested parties may appear at said hearing and participate therein

in accordance with the rules of the Planning Board and Board of Adjustment

Respectfully,

Applicant Signature Krysta Gleeson Parker / Eric

Date: 1/12/2026

TOM

2-1

AFFIDAVIT OF PUBLICATION

Order Number : 11992990

STATE OF WISCONSIN  
Brown County

Of the **Asbury Park Press**, a newspaper printed in Freehold, New Jersey and published in Neptune, in State of New Jersey and Monmouth/Ocean Counties, and of general circulation in Monmouth/Ocean Counties, who being duly sworn, depose and saith that the advertisement of which the annexed is a true copy, has been published in said newspaper in the issue:

01/14/2026

RECEIVED

JAN 21 2026

L.B. SEWERAGE AUTHORITY

*[Handwritten signature]*  
\_\_\_\_\_  
Legal Clerk

*Denise Roberts*  
\_\_\_\_\_  
Notary Public State of Wisconsin County of Brown

*4-6-27*

\_\_\_\_\_  
My commission expires

DENISE ROBERTS  
Notary Public  
State of Wisconsin

*TOM/FICE*

*2-2*

PUBLIC NOTICE  
OFFICIAL INTERNET WEBSITE FOR  
PUBLIC NOTICES / LEGAL  
NOTICES LONG BRANCH SEWERAGE  
AUTHORITY, MONMOUTH COUNTY

TAKE NOTICE that pursuant to P.L.  
2025, c. 72, the complete text of  
each public notice / legal notice of  
the LONG BRANCH SEWERAGE  
AUTHORITY, MONMOUTH COUNTY  
may be obtained or viewed by the  
public on our official Internet  
Website:  
[https://www.lbsa.net/public-  
notices/](https://www.lbsa.net/public-notices/)  
1/14/2026 (9.24)

AFFIDAVIT OF PUBLICATION

Order Number : 12010909

STATE OF WISCONSIN  
Brown County

Of the **Asbury Park Press**, a newspaper printed in Freehold, New Jersey and published in Neptune, in State of New Jersey and Monmouth/Ocean Counties, and of general circulation in Monmouth/Ocean Counties, who being duly sworn, deposeth and saith that the advertisement of which the annexed is a true copy, has been published in said newspaper in the issue:

01/22/2026

RECEIVED

JAN 28 2026

L.B. SEWERAGE AUTHORITY

Legal Clerk

*K. G.*

*Denise Roberts*

Notary Public State of Wisconsin County of Brown

*4-27*

My commission expires

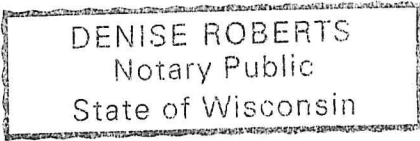

TOM File

2-3

PUBLIC NOTICE  
LONG BRANCH SEWERAGE AUTHORITY, MONMOUTH COUNTY  
OFFICIAL INTERNET WEBSITE FOR PUBLIC NOTICES AND LEGAL NOTICES

TAKE NOTICE that pursuant to P.L. 2025, c. 72, the complete text of each public notice and legal notice of the LONG BRANCH SEWERAGE AUTHORITY, MONMOUTH COUNTY may be obtained or viewed by the public on our official public notice website: <https://www.lbsa.net/public-notices/> and also may be accessed via a button labeled "Public Notices - Click Here" located on the front of the LONG BRANCH SEWERAGE AUTHORITY'S homepage website: <https://www.lbsa.net/>

TAKE FURTHER NOTICE, the New Jersey Department of State (NJDOS) has been tasked with providing a statewide listing of legal notices pages. The NJDOS has announced that it is currently working to finalize the hyperlink intake process. A "Statewide Legal Notices" button is available on the NJDOS website at: <https://www.nj.gov/state/> The Statewide Legal Notices Listing webpage is located at: <https://www.nj.gov/state/statewide-legal-notices-list.shtml>  
(\$21.12)

RECEIVED

JAN 29 2026  
Certified  
L.B. SEWERAGE AUTHORITY

NOTICE OF PUBLIC HEARING

IN THE MATTER OF THE APPLICATION 317 NORWOOD AVENUE  
BLOCK 105, LOT 17 LONG BRANCH, NJ 07740

PLEASE TAKE NOTICE, that a public hearing will be held on Monday, February 9, 2026 at 7:00 PM by the Zoning Board of the City of Long Branch at the City of Long Branch City Hall Meeting Room located at 344 Broadway, Long Branch, New Jersey to consider the application of the Estate of Louis DeLauro requesting a Certificate of Nonconforming Use as a lawful 2-family dwelling in the R-2, single-family zone.

Applicant purchased the property as a 2-family home in 1996 and seeks to continue the use of same as a 2-family home and has filed an application with the City of Long Branch requesting a Certificate of Nonconforming Use to allow the use as a 2-family to continue.

Applicant also expressly makes application for any additional exceptions, interpretations, waivers, variances and other approvals as reflected on the filed plans as same may be further amended from time to time without further notice and as may be determined to be necessary by the Board or its professionals during the review and processing of the application.

PLEASE TAKE FURTHER NOTICE that you are hereby notified that you are privileged to be present at said hearing and you may present any and all objections that you might have as it relates to the granting of said Certificate of Nonconforming Use for this application. Any and all plans and other documents submitted in support of this application are on file with the Long Branch Zoning Board Secretary and are available for inspection between the hours of 9:00AM and 4:00 PM at the office of the Long Branch Zoning Board, 344 Broadway, Long Branch, NJ 07740.

Carol Zocco  
Rosario Realty

Tom, File

2-4

RECEIVED

JAN 29 2026

CERTIFIED  
L.B. SEWERAGE AUTHORITY

NOTICE OF PUBLIC HEARING

IN THE MATTER OF THE APPLICATION 657 CAMPBELL AVENUE  
BLOCK 166, LOT 1 LONG BRANCH, NJ 07740

PLEASE TAKE NOTICE, that a public hearing will be held on Monday, February 9, 2026 at 7:00 PM by the Zoning Board of the City of Long Branch at the City of Long Branch City Hall Meeting Room located at 344 Broadway, Long Branch, New Jersey to consider the application of Vincent & Debbi Todaro requesting a Certificate of Nonconforming Use as a lawful 2-family dwelling in the R-4, single-family zone.

Applicant purchased the property as a 2-family home and seeks to continue the use of same as a 2-family home and has filed an application with the City of Long Branch requesting a Certificate of Nonconforming Use to allow the use as a 2-family to continue.

Applicant also expressly makes application for any additional exceptions, interpretations, waivers, variances and other approvals as reflected on the filed plans as same may be further amended from time to time without further notice and as may be determined to be necessary by the Board or its professionals during the review and processing of the application.

PLEASE TAKE FURTHER NOTICE that you are hereby notified that you are privileged to be present at said hearing and you may present any and all objections that you might have as it relates to the granting of said Certificate of Nonconforming Use for this application. Any and all plans and other documents submitted in support of this application are on file with the Long Branch Zoning Board Secretary and are available for inspection between the hours of 9:00AM and 4:00 PM at the office of the Long Branch Zoning Board, 344 Broadway, Long Branch, NJ 07740.

Carol Zocco  
Rosario Realty

Tom, File

2-5

AFFIDAVIT OF PUBLICATION

Order Number : 12023813

STATE OF WISCONSIN  
Brown County

Of the **Asbury Park Press**, a newspaper printed in Freehold, New Jersey and published in Neptune, in State of New Jersey and Monmouth/Ocean Counties, and of general circulation in Monmouth/Ocean Counties, who being duly sworn, deposeth and saith that the advertisement of which the annexed is a true copy, has been published in said newspaper in the issue:

01/25/2026

*[Handwritten signature]*

Legal Clerk

*[Handwritten signature]*

Notary Public State of Wisconsin County of Brown

*[Handwritten initials]*

My commission expires

RECEIVED

JAN 30 2026

L.B. SEWERAGE AUTHORITY

DENISE ROBERTS  
Notary Public  
State of Wisconsin

*DM, file*

*2-6*

PUBLIC NOTICE  
LONG BRANCH SEWERAGE AUTHORITY, MONMOUTH COUNTY  
OFFICIAL INTERNET WEBSITE FOR PUBLIC NOTICES AND LEGAL NOTICES

TAKE NOTICE that pursuant to P.L. 2025, c. 72, the complete text of each public notice and legal notice of the LONG BRANCH SEWERAGE AUTHORITY, MONMOUTH COUNTY may be obtained or viewed by the public on our official public notice website: <https://www.lbsa.net/public-notices/> and also may be accessed via a button labeled "Public Notices – Click Here" located on the front of the LONG BRANCH SEWERAGE AUTHORITY'S homepage website: <https://www.lbsa.net/>

TAKE FURTHER NOTICE, the New Jersey Department of State (NJDOS) has been tasked with providing a statewide listing of legal notices pages. The NJDOS has announced that it is currently working to finalize the hyperlink intake process. A "Statewide Legal Notices" button is available on the NJDOS website at: <https://www.nj.gov/state/> The Statewide Legal Notices Listing webpage is located at: <https://www.nj.gov/state/statewide-legal-notices-list.shtml>  
(\$21.12)

101 Crawford's Corner Road  
Suite 3400  
Holmdel New Jersey 07733  
Main: 877 627 3772  
Colliersengineering.com



February 2, 2026

RECEIVED

FEB 2 2026

L.B. SEWERAGE AUTHORITY

**VIA EMAIL**

Stephen Musto, P.E.  
InSite Engineering, LLC  
1955 Route 34, Suite1A  
Wall, New Jersey 07719

Branchport Crossing  
336 Branchport Avenue  
Block 357; Lots 2, 3, 4 & 5  
City of Long Branch, Monmouth County, New Jersey  
Colliers Engineering & Design Project No. LBS-0342

Dear Mr. Musto,

Please be advised that I have received the revised documents for the above-referenced application and have found the documents to be acceptable and in conformance with our February 19, 2025 Review Letter.

The following documents were reviewed:

- Plans entitled, "Preliminary and Final Major Site Plan for Branchport Crossing, Block 357; Lots 2, 3, 4, & 5, Tax Map Sheet #33, 336 Branchport Avenue, City of Long Branch, Monmouth County, New Jersey" Sheets C101, C200, C400 and C703, dated September 20, 2023, last revised February 20, 2025;
- Sanitary Sewer Report & Technical Specifications dated December 2, 2024, last revised February 20, 2025;
- Engineering response letter dated February 21, 2025;
- NJDEP TWA-1 Form; and,
- NJDEP WQM-006 Form;

Outstanding conditions of approval include compliance with the following:

1. The Applicant's compliance with any additional revisions/comments that may be required upon review of submittal and/or resubmittal documents.
2. Prior to acceptance, As-Built Plans, both in electronic and paper formats, for the sanitary sewer improvements, shall be submitted to LBSA for review and approval.

Tom. File

2-7

3. Submission of two (2) signed and sealed originals and one (1) PDF copy of the Plumbing Plans. Plumbing Plans must comply with Section 7A.6 "Elevation of Sanitary Fixtures" of the LBSA Rules and Regulations.
4. Submission of two (2) signed and sealed originals and one (1) PDF copy of the Architectural Plans.
5. Submission of a Performance Bond or Letter of Credit in the amount of 120% of the Sanitary Sewer Construction Cost Estimate, calculated to be \$25,649.28. It is required that the Performance Bond be submitted prior to the start of construction.
6. Submission of Engineering Inspection Fees in the amount of 10% of the Sanitary Sewer Construction Cost Estimate, calculated to be \$2,147.44. It is required that the Engineering Inspection Fees be submitted prior to the start of construction.
7. Submission of Connection Fees in the amount of \$260,676.66, based upon a total of forty-eight (48) new residential units, and 4,318 sf of retail, less nine (9) existing equivalent unit credit, as calculated below:

$$4,210 \text{ sf of retail} \times 0.10 \text{ gpd/sf} = 421.0 \text{ gpd}$$

$$421.0 \text{ gpd at the current rate of } \$29.46/\text{gpd} = \$12,402.66$$

$$\text{Forty-eight (48) proposed units} - \text{nine (9) existing units} = \text{thirty-nine (39) net units at the current rate of } \$6,366.00 \text{ per unit} = \$248,274.00$$

$$\text{Total Connection Fee} = \$12,402.66 + \$248,274.00 = \$260,676.66$$

The Connection Fee above is based upon information provided in the previously referenced Transmittal Letter and is subject to change based upon actual facilities/units proposed verified by Architectural Plans, once submitted.

Payment of 50% of the Connection Fees is required prior to the issuance of a Building Permit for each building, and the remaining 50% of the Connection Fees prior to the issuance of a Certificate of Occupancy for the building.

The Applicant is advised that the Connection Fee due is based upon the Connection Fee Rate in effect at the time of payment and is subject to change accordingly.

8. Per LBSA Rules and Regulations 8.5 Performance Guarantee and Insurance, Subsection (f), the Applicant shall provide sign-off as follows:

The Applicant shall agree to indemnify and save harmless the LBSA, its officers, Engineers, agents and servants from and against any loss, resulting from negligence or the fault of the applicant in

the case of work covered by the application. Further, the Applicant shall also indemnify and save harmless the LBSA (including costs of providing a defense) against any damage done to other utilities arising out of the applicant's operation, and name LBSA as an additional insured on their general liability policy.

9. Two (2) weeks prior to the anticipated start of construction, notification shall be provided to LBSA to allow for the scheduling of a pre-construction meeting.
10. Shop drawings for all materials must be submitted to LBSA for approval prior to installation.
11. The operation and maintenance of the sanitary sewer laterals, exclusively serving the Branchport Crossing Development, shall be the responsibility of the property owner(s).
12. Even though operation and maintenance of the sanitary sewer laterals, exclusively serving the Branchport Crossing Development will be the responsibility of the property owner(s) after the facilities have been constructed, the Applicant is required to install the on-site sanitary sewer facilities in accordance with LBSA Standards.

Should you have any questions or require any additional information, please do not hesitate to contact me directly.

Sincerely,

Colliers Engineering & Design, Inc.

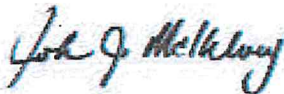

John McKelvey, P.E.  
Senior Project Manger

JJM/DJI/SMB

Application #PB-25-03

Applicant: 129 Joline LLC

RECEIVED

FEB 2 2026  
Certified  
L.B. SEWERAGE AUTHORITY

PLANNING BOARD  
CITY OF LONG BRANCH  
MONMOUTH COUNTY, NEW JERSEY

NOTICE OF HEARING

To: All Property Owners within 200 Feet

PLEASE TAKE NOTICE THAT the undersigned has applied to the Planning Board of the City of Long Branch for a Minor Subdivision from the provisions of the Ordinance so as to subdivide Block 405, Lot 4 of the Tax Map into two residential Lots creating Lots 4.02 and 4.03 and construction of single family residence on proposed lot 4.02 and any and all variances necessary to accommodate the application as filed or as revised by the Planning Board premises located at 129 Joline Avenue, Long Branch, New Jersey 07740; Also known as Block 405, Lot 4 on the Tax Map.

A copy of the Application has been filed in the office of the Planning Board and may be inspected during regular business hours at the Office of Planning Board, 344 Broadway, Long Branch, New Jersey 07740. Please contact the Department of Planning for more information – 732-222-7000 Ext 5430.

A Public Hearing will be held on Tuesday, February 17, 2026 at 7:30 p.m. at City of Long Branch, City Hall, 344 Broadway, 2<sup>nd</sup> Floor, Long Branch, New Jersey 07740 at which time you may appear either in person or by agent or attorney and present any objections which you may have to granting this application.

Dated: 01/27/2026

Louis E. Granata, Esq.

Louis E. Granata, Esq.  
Attorney for the Applicant,  
129 Joline, LLC

TOM, FILE

20

**CITY OF LONG BRANCH  
COUNTY OF MONMOUTH**

**RESOLUTION R-13-26**

**A RESOLUTION REAPPOINTING A MEMBER OF THE LONG BRANCH  
SEWERAGE AUTHORITY**

**BE IT RESOLVED**, by the City Council of the City of Long Branch that the following person are hereby reappointed as a member of the Long Branch Sewerage Authority:

Donald S. Riley

Member

Term Expires Feb. 1, 2031

**MOVED: Vieira**  
**SECONDED: Dangler**

**AYES: 5**  
**NAYS: 0**  
**ABSENT: 0**  
**ABSTAIN: 0**

State of New Jersey  
County of Monmouth  
City of Long Branch

I, Amanda Caldwell, City Clerk of the City of Long Branch, do hereby certify the foregoing to be a true, complete and correct copy of a resolution adopted by the City Council at a Regular Meeting held on February 3, 2026.



City Clerk

TOM/FIVE

2-9

101 Crawfords Corner Road  
Suite 3400  
Holmdel New Jersey 07733  
Main: 877 627 3772



RECEIVED

FEB 4 2026

L.B. SEWERAGE AUTHORITY

February 4, 2026

**VIA EMAIL**

Thomas Roguski, PE, Executive Director  
Long Branch Sewerage Authority  
150 Joline Avenue  
PO Box 270  
Long Branch, New Jersey 07740

Change Order No. 2  
Hoey Pump Station Improvements Project  
Long Branch Sewerage Authority  
City of Long Branch, Monmouth County, New Jersey  
Colliers Engineering & Design Project No. LBS-0330

Dear Mr. Roguski,

We have received Change Order Request No. 2 from Rapid Pump & Meter Service Co., PO Box AY, 285 Straight Street 07509, for NJ 07509, for the Hoey Pump Station Improvements Project. Based upon documents submitted in support of their request and review of the same I recommend approval of Change Order Request No. 2. We have prepared Change Order 2 for review and approval by the Authority and the NJDEP.

Change Order No. 2 consists of the following changes:

1. Modifications to the size and height of the elevated structural platform to accommodate some changes in the final sizes and spacing requirements for the proposed electrical equipment (contract increase);
2. Modifications to the proposed structural grating on the intermediate level of the pump station to facilitate access to the pumps without the need to remove large sections of the grating panels and improve efficiency and safety of maintenance operations (contract increase); and,
3. Change in material for the pump suction elbows to fabricated steel (contract decrease).

Change Order No. 2 results in an overall increase to the contract in the amount of \$22,204.68. The original contract amount was \$1,738,000.00 and the revised contract total amount is \$1,760,204.68.

Attached, please find the following documents for review and approval:

1. NJDEP Change Order No. 2;
2. Construction Bulletin 1 detailing the changes to the size and height of the elevated platform; and,
3. Sketch detailing the changes to structural grating.

TOM.FILP

2-10



Should you have any questions or require additional information, please do not hesitate to contact me directly.

Sincerely,

Colliers Engineering & Design, Inc.

A handwritten signature in black ink that reads "John J. McKelvey".

John J. McKelvey, P.E.  
Senior Project Manager

JJM/dji

Enclosure

cc: Bruce Bradford, Colliers Engineering & Design (via email)

Dominic Ierardi, Colliers Engineering & Design, Inc. (via email)

r:\projects\i-1\lbs\lbs0330\construction\change orders\change order 2\260204\_jjm\_roguski\_co2.docx

**CONTRACT MODIFICATION PROPOSAL AND ACCEPTANCE**

1. ISSUING OFFICE <b>Long Branch Sewerage Authority</b>	2. PROJECT NO. <b>S340336-11</b>	3. CONTRACT NO. <b>LBS0330</b>	4. MODIFICATION NO. <b>2</b>	
5. TO (CONTRACTOR) Rapid Pump & Meter Service Co., LLC PO Box AY/285 Straight Street Paterson, NJ 07509		6. PROJECT LOCATION AND DESCRIPTION Hoey Pump Station Improvements Project		
7. A proposal is required for making the hereinafter described change in accordance with specification and drawing revisions cited herein or listed in attachment hereto. Submit your proposal in space indicated on page 2, attach detailed breakdown of prime and sub-contract costs (See the clause of this contract entitled, "Changes". DO NOT start work under this proposed change until you receive a copy signed by the Contracting Officer or a directive to proceed).				
_____ Date	<u>Thomas Roguski, Executive Director</u> Type Name and Title	_____ Signature		
8. DESCRIPTION OF CHANGE: Pursuant to the clause of this contract covering changes, the contractor shall furnish all labor and material, and all work and equipment necessary to accomplish the following described work:  Proposed increase in size to the elevated equipment platform to accommodate final sizes of electrical equipment.  As a result of the above, the contract price is revised as follows:				
<u>ITEM NO.</u>	<u>ITEM DESCRIPTION</u>	<u>UNIT PRICE</u>	<u>EST. QTY.</u>	<u>TOTAL COST</u>
S-2	Increase in size to elevated equipment platform.	\$16,490.68	1 LS	\$16,490.68
S-3	Removable grating sections modifications/	\$6,995.00	1 LS	\$6,995.00
S-4	Change in material to fabricated steel suction elbows	-\$1,281.00	1 LS	-\$1,281.00
Contractor agrees that the time extension and cost of this Contract Modification (Change Order) shall be full and complete compensation to the Contractor for the Work described herein and, as such, Contractor, its officers, employees, successors and assigns, hereby releases the Owner, its Board Members, officers, employees and consultants of any and all claims, including, but not limited to, disruption, delay, loss of productivity, idle time for persons and equipment, home office overhead, extended or disrupted performance, additional mobilizations, re-mobilizations, indirect or impact claims, loss of profit, together with any other damages, that relate in any way to the Work described in this Contract Modification (Change Order).				
<b>TOTAL COST OF THIS MODIFICATION: \$ 22,204.68</b>				
The contract time is hereby: increased <input type="checkbox"/> decreased <input type="checkbox"/> or remains the same <input checked="" type="checkbox"/> by <u>0</u> calendar days as a result of this modification.				
The foregoing modifications are hereby accepted:				
_____ CONTRACTOR BY: <u>Paul Kearney</u>	_____ OWNER BY: <u>Thomas Roguski</u>	(NJPE SEAL)	_____ ENGINEER BY: <u>John McKelvey, PE</u>	_____ DATE:
APPROVAL: _____				
STATE OF NEW JERSEY			DATE	

**CONTRACT MODIFICATION PROPOSAL AND ACCEPTANCE**

9. ISSUING OFFICE  <b>Long Branch Sewerage Authority</b>	10. PROJECT NO.  <b>S340336-11</b>	11. CONTRACT NO.  <b>LBS0330</b>	12. MODIFICATION NO.  <b>2</b>
13. CONTRACTOR'S PROPOSAL – CHANGE IN CONTRACT PRICE (Detailed breakdown, attach additional sheets as necessary)			
(Proposed)  See attached Change Order Recommendation by John McKelvey of Colliers Engineering & Design, dated February 4, 2026  The Change Order is in agreement with Rapid Pump & Meter Service Co, Long Branch Sewerage Authority, and Colliers Engineering & Design, Inc..			
NET INCREASE \$ <u>22,204.68</u>	NET DECREASE \$ <u>0.00</u>	CALENDER DAYS INCREASE <u>0</u> DAYS	
DATE:	TYPE NAME AND TITLE:  Rapid Pump & Meter Service Co.	SIGNATURE:	

**CONTRACT MODIFICATION PROPOSAL AND ACCEPTANCE**

14. ISSUING OFFICE & PROJECT NO.  <p style="text-align: center;"><b>Long Branch Sewerage Authority S340336-11</b></p>	15. CONTRACT NO.  <p style="text-align: center;"><b>LBS-0330</b></p>	16. MODIFICATION NO.  <p style="text-align: center;"><b>2</b></p>
17. ORIGINAL CONTRACT BID PRICE ..... \$ <u>1,738,000.00</u> TOTAL OF PREVIOUS CHANGE ORDERS ..... \$ -- TOTAL CONTRACT COST INCLUDING CHANGE ORDERS ... \$ <u>1,760,204.68</u>		
18. NECESSITY FOR CHANGE AND REASON FOR OMISSION FROM PLANS AND SPECIFICATIONS:  See attached Change Order Recommendation by John McKelvey of Colliers Engineering & Design, dated February 4, 2026.		
19. OTHER IMPACTS RESULTANT OF THIS CHANGE:  None.		
20. RESUME OF NEGOTIATIONS OR RECOMMENDATIONS (Loanee's Representative) :  See attached Change Order Recommendation by John McKelvey of Colliers Engineering & Design, dated February 4, 2026.		
DATE:	TYPE NAME AND TITLE OF LOANEE'S REPRESENTATIVE:  <p style="text-align: center;">Thomas Roguski, PE Long Branch Sewerage Authority</p>	SIGNATURE:

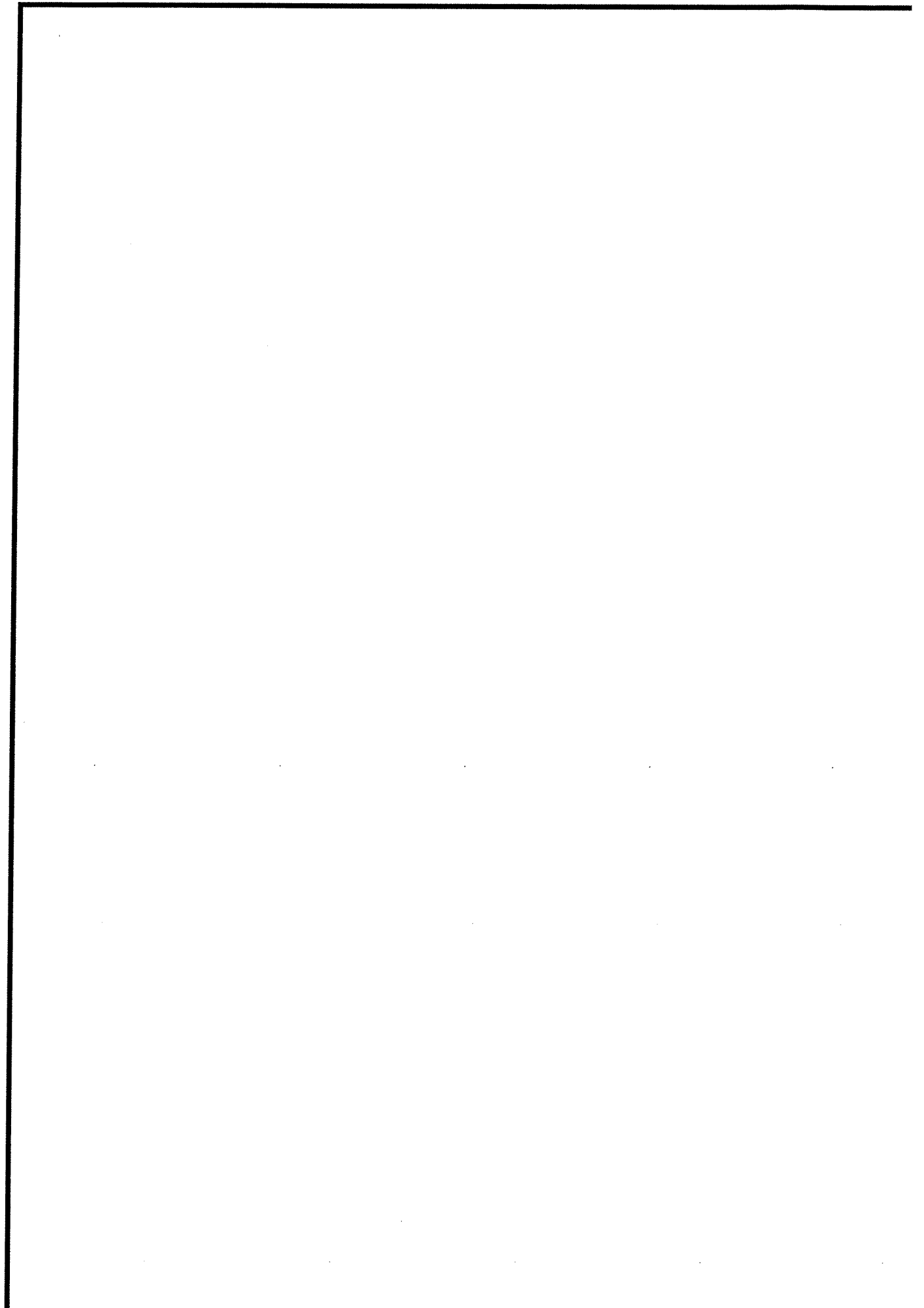

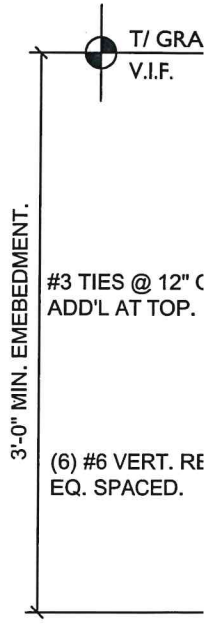
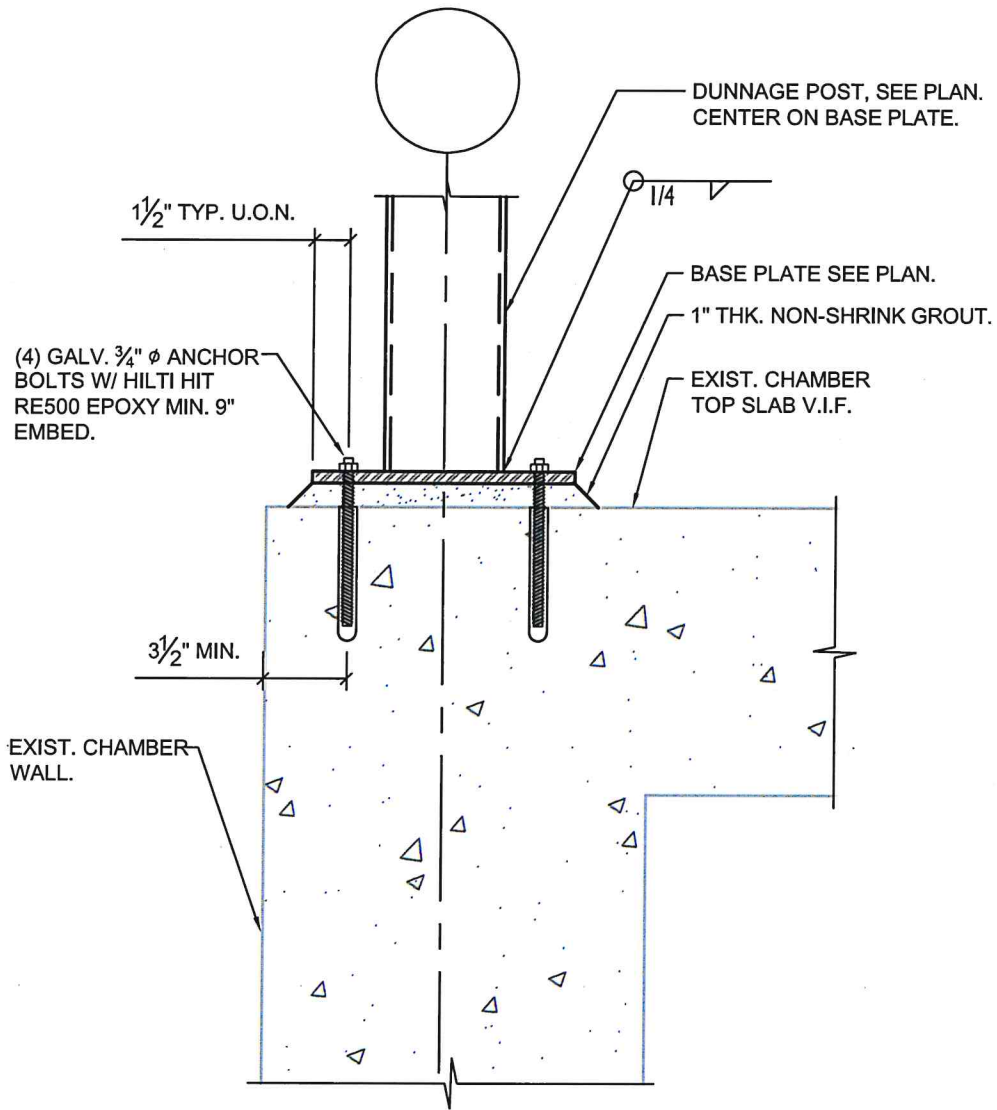

**1** TYP. DUNNAGE POST CONN.  
 SCALE: 1/2" = 1'-0"

- NOTES:**
- ALL POSTS AND POST BASES TO BE CENTERED OVER CHAMBER WALL BELOW. FIELD VERIFY CHAMBER WALL EXTENTS. PRIOR TO FINAL PLACEMENT OF STEEL.

**2** TY  
 SCA

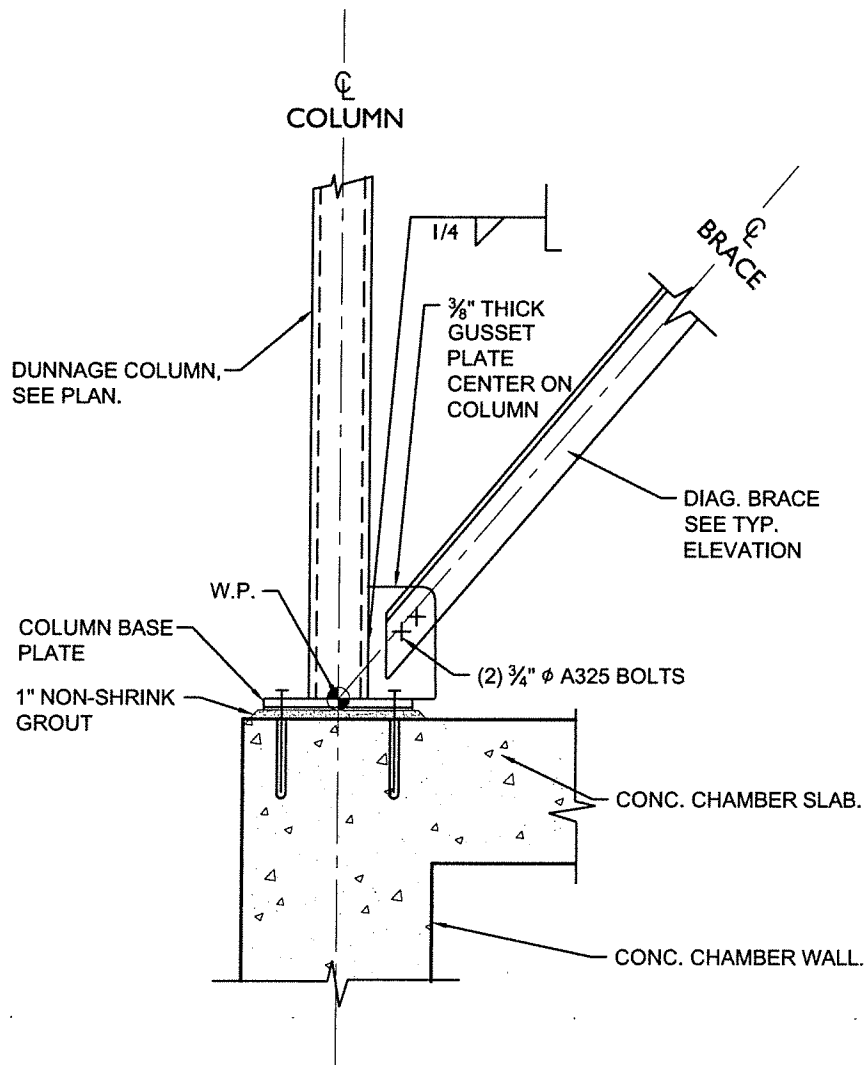

TYP. SHEAR T BEAMS TO CO 5/S-3.1.

(2) 3/4" φ A325 E

HSS 5x5 DUNN COLUMN SEE I

**I** TYP. BOTT. DETAIL AT BRACES

SCALE: 3/4" = 1'-0"

**NOTES:**

1. SEE 1/S-3.1 FOR POST AND BASE PLATE CONNECTION TO CHAMBER.

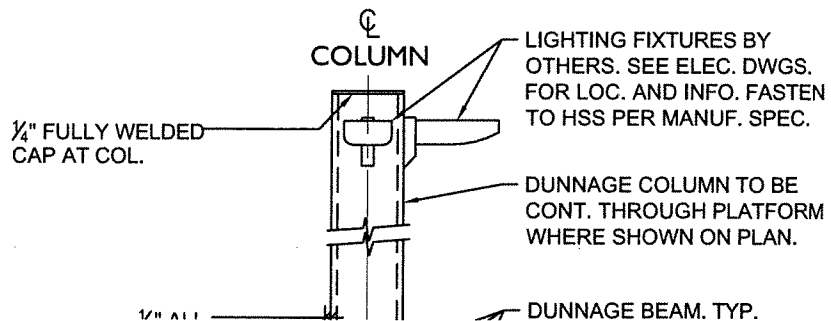



LONG BRANCH SEWERAGE AUTHORITY  
150 JOLINE AVENUE  
P.O. BOX 720  
LONG BRANCH, NJ 07740

RECEIVED

FEB 4 2026

L.B. SEWERAGE AUTHORITY

FORM E-6 (Page 1 of 2)

APPLICATION FOR CHANGE OF USE OF EXISTING SEWERAGE FACILITIES

(UNIT CHANGES)

FILL IN AS EACH ITEM MAY APPLY - USE N/A IF NON-APPLICABLE

Date 02/04/26

Application for CHANGE OF USE OF SEWERAGE FACILITIES IN LONG BRANCH, COUNTY OF MONMOUTH, STATE OF NEW JERSEY. This application must be filed with the Executive Director of the Authority. Please answer all questions.

Application is hereby made for a change of use of existing sewerage facilities for a ruling on the system layout, characteristics, capacity, and requirements.

1. Applicant's Name Jang Singh (532 Broadway 11c)  
Address ~~532 B~~ 10 Zachary way  
Eaton town NJ 07724 Phone (732) 939 3641  
Contact Person Name Jang Singh Phone (732) 939 3641
2. Name of Present Property Owner Jang Singh  
Address 10 Zachary way Eaton town  
NJ- 07724 Phone (732) 939 3641
3. Interest of applicant if other than owner of property \_\_\_\_\_
4. Key Location or Street Location of Project 536 Broadway  
Long branch NJ 07740  
Block No. 176 Lot No. 37 Unit C

Tom, etc

2-11

FORM E-6 (Page 2 of 2)

(UNIT CHANGES) 3 to 2 units

5. Describe: a) prior use Chinese Restaurant with  
b) new use Bath<sup>room</sup> removed & combined, Convenience store
6. Effective Date of Change of Use 02/04/26

7. Owner and applicant have read the LBSA Rules and Regulations and fully understand all necessary requirements. Yes

All sewer service charges must be paid up to date in order for the unit change to be effective.

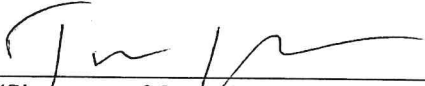
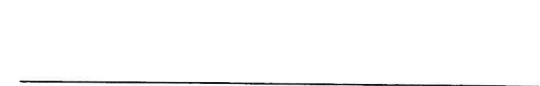
 _____ (Signature of Owner)	 _____ (Signature of Applicant)
<u>Jang Singh</u> _____ (Name of Owner, typed/printed)	_____ (Name of Applicant, typed/printed)
<u>Member</u> _____ (Owner's Position or Title)	_____ (Applicant's Position or Title)

8. Inspectors Report \_\_\_\_\_

**NOTICE OF HEARING  
CITY OF LONG BRANCH  
ZONING BOARD  
Applicant: Summerfield Avenida LLC  
Block: 258 Lot: 14  
54 Dudley Street  
Long Branch, NJ 07740**

**RECEIVED**

FEB 6 2026  
*certified*  
L.B. SEWERAGE AUTHORITY

PLEASE TAKE NOTICE THAT the Zoning Board of the City of Long Branch will hold a public meeting on 23rd day of February 2026 at 7:00 p.m. in the Council Chambers, City Hall, 344 Broadway, Long Branch, NJ 07740, to consider the application of the property known as Block: 258, Lot: 14, on the Tax Map of the City of Long Branch, more commonly known as 54 Dudley Street, Long Branch, NJ 07740

The applicant requests variance relief for the following:

1. Minimum front yard setback, 25 sq. ft. is required, whereas 15.0 sq. ft is proposed.
2. Minimum one side yard setback, 10 ft. is required whereas 5.0 ft. is proposed.

The applicants reserve the right to request any and all necessary waivers or variances that may become apparent in the course of review and at the time of hearing.

The matter will be heard on the date indicated above at the Municipal Chambers at the City of Long Branch, 344 Broadway, Long Branch, New Jersey (City Hall).

You may review the application, submissions in support of the application and review letters by contacting/visiting the planning board secretary at 344 Broadway, Long Branch, New Jersey between the hours of 8:30 and 4:30 p.m., Monday through Friday, legal holidays excepted.

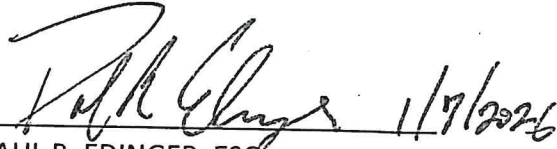
  
PAUL R. EDINGER, ESQ.  
489 Broadway  
Long Branch, NJ 07740  
(732)222-3424

Tom. File

2.12

RECEIVED

FEB 9 2026

L.B. SEWERAGE AUTHORITY



**New Jersey Water  
Environment  
Association  
PRESENTS**



**THE  
2026  
Winter Technology  
Transfer Seminar**

**MARCH 9 – MARCH 12, 2026  
Sheraton Eatontown Hotel  
6 Industrial Way • Eatontown, NJ • 732-542-6500**

**NJWEA Officers**

- Francis Bonaccorso ..... President
- Michael J. Hope, P.E. .... President Elect
- Brian J. Brach, P.E. .... Vice President
- Robert Fischer ..... Treasurer
- James De Block. .... Executive Director
- Richard Eustace ..... Deputy Executive Director

FEB 16 2026  
Certified

**BOROUGH OF WEST LONG BRANCH ZONING BOARD  
NOTICE OF HEARING  
PUBLIC NOTICE**

**PLEASE TAKE NOTICE**, that Stephen Schulz hereby appeals the granting of the Zoning Permit #2024-422 issued for the property located at 65 Summers Avenue, West Long Branch, New Jersey (Block 71, Lots 14.01 and 14.02). The property is located in the R-22 Low Density Residential Zone. Stephen Schulz specifically appeals the granting of Zoning Permit 2024-422 approving the construction of the new home as per the plans prepared by John A. Buletza, P.E., dated November 11, 2024, last revised on November 15, 2024 on the grounds that the variances approved by the West Long Branch Planning Board by way of Resolution of Approval granted on June 12, 2018, expired without proper extension. The construction of the new home exceeds the bulk requirements by violating the side yard setbacks permitted by the Borough of West Long Branch Ordinance as the current construction has an existing 15 foot side yard setback whereas a 20 foot setback is required. The existing construction also has an existing 30 foot total side yard setback in which 50 feet is required. The existing construction of 7,000 square feet exceeds the square footage of the plans filed with the Application and approved by the Resolution. The construction also requires a height variance exceeding 35 feet, in which none was applied by the Applicant.

Stephen Schulz reserves the right to appeal any other issues regarding Zoning Permit #2024-422 as may arise during the public hearing process.

The application is scheduled for a public hearing on **Tuesday, February 17, 2026 at 7:00 p.m.** prevailing time, in the Council's Chambers at the Borough of West Long Branch, Borough Hall, 965 Broadway, West Long Branch, New Jersey 07764, at which time you may appear, either in person, or by agent, or attorney, and present any comments, objections, or questions which you may have to this appeal, and/or any component parts thereof.

NOT LBSA

2-14

Copies of pertinent documents are available for public inspection Monday through Friday, at the office of the Borough of West Long Branch Planning and Zoning Secretary, located at the Borough of West Long Branch, 965 Broadway, West Long Branch, New Jersey 07764.

This notice is sent to you by the attorney for an objector to a prior Resolution of Approval as required by the Board.

02/02/2026

Date

*S/ Richard C. Sciria*

Richard C. Sciria, Esq.  
Hanlon, Niemann & Wright, P.C.  
Attorney for Applicant  
83 South Street, Suite 301  
Freehold, NJ 07728  
732-863-9900 Ext. 0108

101 Crawfords Corner Road  
Suite 3400  
Holmdel New Jersey 07733  
Main: 877 627 3772

RECEIVED

FEB 12 2026

L.B. SEWERAGE AUTHORITY



Engineering  
& Design

February 11, 2025

**VIA EMAIL**

Thomas Roguski, P.E., CME, Executive Director  
Long Branch Sewerage Authority  
150 Joline Avenue  
P.O. Box 720  
Long Branch, New Jersey 07740

Engineer's Status Report  
February 2026 Meeting  
Colliers Engineering & Design Project No. LBS-001

Dear Mr. Roguski,

The following is a report on the status of projects for which Colliers Engineering & Design, Inc. (CED) is responsible:

**1. Capital Projects**

**a. WWTP Expansion Study (LBS-0329)**

Report reviewed at the January 2025 board meeting. Meeting to be scheduled by LBSA with the Engineering Committee to discuss further.

**b. Hoey Pump Station Improvements (LBS-0330)**

Submittal review and coordination with the contractor is ongoing. Contractor anticipates the majority of the upgrade work to start in early spring 2026. The NJDEP conducted their first interim inspection on October 24, 2025. No issues or concerns were raised by the DEP during their inspection. As discussed at previous meetings, CED has been reviewing a proposed change to the size of the elevated platform due to final sizes and spacing of electrical equipment to be installed on the platform. In addition to the platform change, in working with the contractor on the removable access panels for lifting the pumps, it was determined some further modifications to the removable structural grating above the pumps were required to provide the Authority with easy, safe pump access without the need to remove entire grating sections. CED has prepared a change order for review and approval by the Authority and the DEP that covers the above changes. Note that the change order also includes a credit for a change in material to fabricated steel for the pump suction elbows.

TOM.

2.15

## 2. Active Escrow Projects

### a. 180 Morris Avenue (in construction) (LBS-289)

All construction work is complete and final testing and inspections have been performed. Project closeout contingent on completion of completion of punchlist items and submission of outstanding administrative items.

### b. Takanassee (in construction) (LBS-290)

The sanitary main and laterals have been installed. Final testing is complete. Updated punch list was sent to Applicant on October 23, 2024. Developer working on building construction.

### c. Proposed 7-Eleven (LBS-292)

Approval letter was sent to the Applicant on January 7, 2021.

### d. Beachfront LLC (in construction) (LBS-294)

One lateral has been installed and awaits final inspection. Three remaining laterals to be installed at a future date.

### e. Broadway Place (Phase I/II) (in construction) (LBS-295)

The majority of sanitary sewer installation construction work within Broadway is complete and pending final inspection, testing and preparation of a punchlist. The revised plans submitted by the applicant has been reviewed and approved, construction of the sanitary sewer lateral is ongoing.

### f. NJDOT Bridge over Troutman's Creek (LBS-315)

A meeting with NJDOT took place on Friday, June 10, 2022. Follow up meetings with the NJDOT consulting engineer have been held on April 30, 2025 and on June 4 2025 to discuss recently submitted updated NJDOT utility plans and specifications. Revised documents have been submitted, reviewed and deemed acceptable. The final documents were forwarded to the Authority for endorsement and subsequently forwarded to NJDOT. The Authority will be notified in advance of any of the proposed construction activities that will impact sewer facilities. Additional escrow has been requested from the NJDOT to cover engineering services during construction. The project is currently out to bid, Contractor's have submitted questions regarding bypass requirements of lining work. The Authority and CED have provided input and clarification for the bidders.

**g. Ocean Gate (in construction) (LBS-0316)**

All construction work is complete and final testing and inspections have been performed. All construction related punchlist items have been satisfactorily addressed. Project closeout contingent on submission of outstanding administrative items. The applicant is currently preparing revised as-builts for review and approval.

**h. 175 Chelsea Avenue (LBS-0317)**

A review letter was sent on June 8, 2021 to the Applicant. A revised submission was made, and a letter was sent to the Applicant on September 9, 2021, outlining remaining items to be submitted.

**i. 290 Ocean Avenue (LBS-0321)**

A review letter was sent on January 10, 2022 to the Applicant.

**j. 279 Third Avenue (LBS-0326)**

A review letter was sent to the Applicant on October 3, 2022.

**k. The Atlantic Club (in construction) (LBS-0334)**

Preconstruction meeting was held. Construction start date pending submission, review and approval of administrative items. National Water Main has completed CCTV inspection of the existing main to be lined along S. Bath Avenue. Coordination for the completion of lining work and sanitary sewer work is ongoing.

**l. Santos Subdivision (LBS-0004)**

The applicant has submitted revised plans proposing individual grinder pumps for approval, the NJDEP has confirmed that a TWA will be required for the application. The applicant has satisfactorily addressed all comments and the Authority has endorsed the TWA application.

**m. 156-164 Franklin Avenue (in construction) (LBS-0005)**

Construction of sewer facilities and final testing are complete. Final inspection to be scheduled and punchlist to be issued upon completion of inspection. Developer is constructing buildings in phases. The applicant has requested COs for Lots 5.02, 5.03 and 5.04, inspections for the same have been completed.

**n. Second Avenue Multi-Use Development (in construction) (LBS-0336)**

All closeout documentation has been received, and the application has been closed out. Application to be removed from the active applications list in the following Engineer's Status Report.

**o. 169 Chelsea Avenue (in construction) (LBS-0338)**

Revised plans to eliminate proposed deep connections to existing sewer have been reviewed and approved. The contractor has installed three (3) sanitary sewer laterals of 3 to be constructed and connected to an existing manhole per the approved plans.

**p. 333-345 Second Avenue Proposed Townhouse Development (in construction) (LBS-0339)**

All construction work is complete and final testing and inspections have been performed. All construction related punchlist items have been satisfactorily addressed. Project closeout contingent on submission of outstanding administrative items.

**q. Ocean Acre (in construction) (LBS-0340)**

Preconstruction meeting was held September 12, 2025. Construction start date pending submission, review and approval of administrative items.

**r. Branchport Crossing (LBS-0342)**

Conditional approval letter was provided to the Applicant on February 21, 2025. TWA approval has been received.

**s. Monmouth University BSACAM (in construction) (LBS-0344)**

Sanitary sewer construction is complete and final testing remains to be completed. Final inspection to be scheduled and punchlist to be issued upon completion of inspection.

**t. Sephardic Torah Temple (LBS-0345)**

The application received conditional approval at the October 2024 meeting. Notice has been sent to the Applicant. Resubmission documents have been reviewed and comments provided. Coordinating with the applicant's engineer for completion of a capacity analysis. Cleaning and CCTV of downstream sanitary sewer has been conducted for the purpose of completing the capacity analysis.

**u. RCHP Affordable Housing Corporations (LBS-0346)**

The application received conditional approval at the October 2024 meeting. Notice has been sent to the Applicant. Awaiting submission of revised documents for review and approval.

**v. 201, 213 & 215 Third Ave. (LBS-0347)**

Revised documents have been submitted and reviewed. Review comments were provided November 25, 2025.

**w. Seventh Avenue Apartments (LBS-0349)**

Revised documents have been submitted and reviewed, notice of approval has been sent to the Applicant.

**x. 112 Brighton Avenue (in construction) (LBS-0350)**

Sanitary sewer construction is complete and final testing remains to be completed. Final inspection to be scheduled and punchlist to be issued upon completion of inspection.

**y. 85 Chelsea Avenue (LBS-0351)**

Revised documents have been submitted and reviewed. Review comments were provided December 19, 2025.

**z. 305 Broadway Mixed-Use Development (LBS-0353)**

The application received conditional approval at the August 2025 meeting. Notice has been sent to the Applicant. A capacity study has been completed and the applicant has satisfactorily addressed all comments and the Authority has endorsed the TWA application.

**aa. Wave Condominium (LBS-0354)**

The application received conditional approval at the August 2025 meeting. Notice has been sent to the Applicant. Awaiting submission of revised documents for review and approval.

**bb. 400 Morris Avenue (LBS-0355)**

Revised documents have been submitted and reviewed. Review comments were provided November 14, 2025. Revised documents have been received and are currently under review.

**cc. 648 Second Avenue (LBS-0356)**

The application received conditional approval at the September 2025 meeting. Notice has been sent to the Applicant. Awaiting submission of revised documents for review and approval.

**dd. 83 North Broadway Proposed Mixed-Use Development (LBS-0357)**

Revised documents have been submitted and reviewed. Review comments were provided December 19, 2025.

**ee. 119-127 Brighton Avenue (LBS-0358)**

The application received conditional approval at the November 2025 meeting. Notice has been sent to the Applicant. Revised documents have been received and are currently under review.

Should you have any questions or require any additional information, please do not hesitate to contact me directly.

Sincerely,

Colliers Engineering & Design, Inc.  
(DBA Maser Consulting)



John J. McKelvey, P.E.  
Senior Project Manager

**Long Branch Sewerage Authority**

**150 Joline Avenue**

**P.O. Box 720**

**Long Branch, NJ 07740-0702**

-----  
**(732) 222-0500**

**Fax (732) 222-7947**

Donald S. Riley  
Chairman

Michael Booth  
Vice-Chairman

David G. Brown  
Secretary

Bryan I. Larco  
Treasurer

Susie Morris  
Asst. Sec. Treas.

Thomas Roguski, PE, CME  
Executive Director

Fallon & Co., LLP  
Accountants

Colliers Engineering & Design  
Consulting Engineers

Manna & Bonello, P.A.  
Counsel

RECEIVED

FEB 12 2026

L.B. SEWERAGE AUTHORITY

February 12, 2026

Kevin J. Hayes, Sr.  
InSite Engineering, LLC  
1955 Route 34, Suite 1A  
Wall, NJ 07719

VIA EMAIL

Re: Long Branch Sewerage Authority  
Letter of Service Availability: Sanitary Sewer  
1199 Lincoln Square  
Block 11, Lot 1  
City of Long Branch, Monmouth County, New Jersey

Dear Mr. Hayes:

Please be advised that we have received your February 10, 2026 letter requesting a Letter of Service Availability for Sanitary Sewer for a proposed two-unit duplex addition to the existing building at the above referenced property. It is understood that Lot 1 shall remain as a single lot, with all existing and proposed improvements thereon. Based upon our review of the information presented in your letter, the Long Branch Sewerage Authority (LBSA) currently has capacity at its wastewater treatment plant to serve the proposed two-unit duplex addition, at 1199 Lincoln Square, Block 11, Lot 1, in the City of Long Branch, New Jersey.

In order to reserve capacity for the project, a complete Application for Individual Connection of Residential Sanitary Sewer into Existing Long Branch Sewerage Authority System (Form E-1) must be submitted to and approved by the LBSA, and payment of Connection Fees, Construction Costs, and all other applicable fees must be made and other conditions met. A new sanitary sewer lateral shall be required to be installed from the sanitary sewer main in the street to the building, at the Applicant's cost, by the Authority's Contractor. The onsite sanitary sewer lateral is the responsibility of the Applicant.

Should you have any questions, or require additional information, please do not hesitate to contact me.

Very truly yours,

LONG BRANCH SEWERAGE AUTHORITY



Thomas Roguski, PE, CME  
Executive Director

RECEIVED

AFFIDAVIT OF PUBLICATION

FEB 13 2026

Order Number : 12063715

STATE OF WISCONSIN  
Brown County

L.B. SEWERAGE AUTH

Of the **Asbury Park Press**, a newspaper printed in Freehold, New Jersey and published in Neptune, in State of New Jersey and Monmouth/Ocean Counties, and of general circulation in Monmouth/Ocean Counties, who being duly sworn, depose and saith that the advertisement of which the annexed is a true copy, has been published in said newspaper in the issue:

02/08/2026

*K. Lynn*  
\_\_\_\_\_  
Legal Clerk

*Denise Roberts*  
\_\_\_\_\_  
Notary Public State of Wisconsin County of Brown

*4-6-27*  
\_\_\_\_\_  
My commission expires

DENISE ROBERTS  
Notary Public  
State of Wisconsin

TOM, File

2-17

PUBLIC NOTICE  
LONG BRANCH SEWERAGE AUTHORITY, MONMOUTH COUNTY  
OFFICIAL INTERNET WEBSITE FOR PUBLIC NOTICES AND LEGAL NOTICES

TAKE NOTICE that pursuant to P.L. 2025, c. 72, the complete text of each public notice and legal notice of the LONG BRANCH SEWERAGE AUTHORITY, MONMOUTH COUNTY may be obtained or viewed by the public on our official public notice website: <https://www.lbsa.net/public-notices/> and also may be accessed via a button labeled "Public Notices – Click Here" located on the front of the LONG BRANCH SEWERAGE AUTHORITY'S homepage website: <https://www.lbsa.net/>

TAKE FURTHER NOTICE, the New Jersey Department of State (NJDOS) has been tasked with providing a statewide listing of legal notices pages. The NJDOS has announced that it is currently working to finalize the hyperlink intake process. A "Statewide Legal Notices" button is available on the NJDOS website at: <https://www.nj.gov/state/> The Statewide Legal Notices Listing webpage is located at: <https://www.nj.gov/state/statewide-legal-notices-list.shtml>  
2/8/2026 (\$21.12)

# CANNON MCGUINN

A LIMITED LIABILITY COMPANY

P.O. Box 948  
Matawan, New Jersey 07747

105 Reids Hill Road – Suite B  
Aberdeen, New Jersey 07747

Phone: (732) 904-8622  
Fax: (732) 362-4539

Gregory J. Cannon, Esq. – Member

E-Mail: gcannon@cmlawnj.com

February 4, 2026

**Via Hand Delivery**

Thomas Roguski, Exec. Director  
Long Branch Sewerage Authority  
150 Joline Avenue  
Long Branch, New Jersey 07740

**Re: Response to Long Branch Sewerage Authority RFP – General Attorney/Counsel**  
**Term: February 2026 to February 2027**

Dear Mr. Roguski:

Please accept this letter, together with the enclosed materials, in response to the Long Branch Sewerage Authority's RFP for General Attorney/Counsel.

Specializing in public entity liability, real estate, municipal court matters, construction, OPRA, OPMA, land use, tax lien, cannabis regulation, and public labor/employment law, Cannon & McGuinn, LLC is able to provide a superior level of service to our public and private clients. Indeed, personal service is one of our firm's core values.

For over a decade, I have a proven track record of success serving public entities throughout the State of New Jersey. Presently, I serve in the following public capacities:

- Borough Attorney for the Borough of Roosevelt.
- Borough Attorney for the Borough of Allentown.
- Borough Attorney for the Borough of Bradley Beach.
- Borough Attorney for the Borough of Red Bank.
- Borough Attorney for the Borough of Neptune City.
- Village Attorney for the Village of Loch Arbour.
- Harbor Commission Attorney for the Borough of Atlantic Highlands.
- Zoning Board Attorney for the City of Long Branch.
- Labor Attorney for the Long Branch Sewerage Authority.
- Tax Appeal Attorney for the Borough of Belmar.
- Special Counsel for the Borough of Matawan.

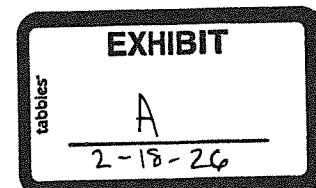

If selected, my law partner, William G. McGuinn, Esq., and I will be responsible for fulfilling the position. The primary point of contact will be our cellphones – not an answering service or receptionist. It is this personal engagement that sets us apart from larger competitors.

In addition to serving the legal needs of New Jersey public entities, I am also committed to public service outside of work. I have served as a Councilman and Mayor in my hometown of Aberdeen for over sixteen years. Through my personal experiences as a municipal official, I have gained an in-depth understanding of the complex issues presented to public entities and the nuances of interacting with a sometimes-difficult public.

Being a public entity's attorney requires more than just knowing and applying the law. It requires an understanding of how to firmly, but respectfully, interact with your residents, and how to appropriately handle sometimes difficult situations. I am one of the few municipal attorneys who can promise expertise in that arena. My personal experience as an elected official has allowed me to see the legal process from the perspective of a governing body member – not just as a lawyer.

If fortunate enough to be appointed, I will bring a wealth of experience to the position, having ably represented public entities before administrative tribunals and courts of law for the last fourteen years. As you can see from the foregoing, I serve as general counsel to multiple and varied public entities, and possess substantial experience in all realms of public entity law.

As requested, I enclose herewith my *Curriculum Vitae* and all other completed forms and documents required by the Authority's RFP.

Thank you in advance for your time and consideration. If you have any questions or require further information, please do not hesitate to contact me.

Sincerely,



Gregory J. Cannon, Esq.

GJC  
Enclosures

**CERTIFICATION REQUIRED BY THE LOCAL FINANCE BOARD**

I, THOMAS ROGUSKI, EXECUTIVE DIRECTOR OF THE LONG BRANCH SEWERAGE AUTHORITY, COUNTY OF MONMOUTH, HEREBY CERTIFY THAT THERE ARE FUNDS AVAILABLE FOR THE PURPOSE OF AWARDING A CONTRACT AND/OR EXPENDING FUNDS FOR THE PURPOSE IDENTIFIED BELOW. THE AMOUNT OF THE CONTRACT AND/OR EXPENDITURE EXCEEDS:   **\$17,500.00**

**PURPOSE: Legal Services**

**ACCOUNT TO BE CHARGED:   *Legal/01-900-001-8008***

**NAME OF PAYEE AND/OR SUCCESSFUL BIDDER:**

**Gregory J. Cannon, Esq.**

**for the firm of Cannon & McGuinn**

**CERTIFICATION DATED: *February 18, 2026***

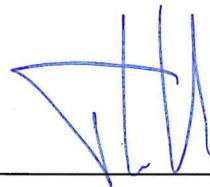

Thomas Roguski, Executive Director

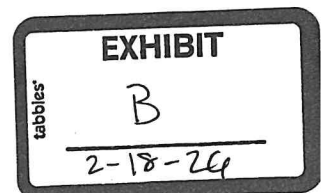

Honorable Chairman and Commissioners  
of the Long Branch Sewerage Authority

Fallon & Company LLP is pleased to have the opportunity to submit this qualification statement to serve as auditor for the Long Branch Sewerage Authority.

Fallon & Company LLP is committed to providing the Authority with service that is both timely and of the highest quality. We have established an excellent record for delivering top-notch accounting, auditing and consulting services to other New Jersey governmental entities and have developed an excellent working relationship with key personnel within those entities.

As the independent auditors for many local governments and governmental entities, we are thoroughly familiar with the specific audit requirements for authorities from both an auditing and operational point of view. This experience makes us thoroughly familiar with applicable statutes, regulations and the operations of government.

Fallon & Company LLP is comprised of a group of dedicated professionals anxious to assist the Authority in fulfilling its audit and accounting needs. The service team that has been assembled to serve the Authority consists of:

Charles J. Fallon, CPA, RMA - Partner (Principal Auditor assigned to the Authority)  
Darrin Kneute, CPA - Manager  
Ross H. Parsells - Staff

The firm has made a major commitment to government by dedicating several of our top professionals to this segment of our business. We understand how to audit in the highly visible government environment. During our term as Authority Auditor, we have acquired an understanding of the Authority and its operations related to its financial environment. This understanding allows us to be uniquely informed of matters that relate to the Authority's financial management and operation.

There are several key factors which demonstrate our enthusiasm, competence, commitment, and ability to be responsive to your needs:

We are a "total service" organization. Our professionals can provide the Authority a full range of accounting, auditing and consulting services.

We are unafraid to apply proven, innovative solutions to the variety of issues facing an organization such as the Authority.

We have a history of providing quality professional services to an impressive list of governmental clients.

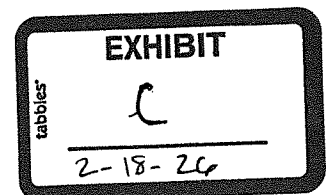

We have developed an audit approach and workplan, presented in the proposal, which will ensure that the State's audit requirements will be achieved.

The qualification statement that follows describes in greater detail Fallon & Company LLP's qualifications and presents a comprehensive approach for serving the Authority.

We will be pleased to respond to any questions or to provide any further information or clarification concerning this qualification statement, as you consider it necessary.

Very truly yours,

Handwritten signature of Charles J. Fallon, CPA, RMA for the firm.

Charles J. Fallon, CPA, RMA for the firm

January 19, 2026

**CERTIFICATION REQUIRED BY THE LOCAL FINANCE BOARD**

I, THOMAS ROGUSKI, EXECUTIVE DIRECTOR OF THE LONG BRANCH SEWERAGE AUTHORITY, COUNTY OF MONMOUTH, HEREBY CERTIFY THAT THERE ARE FUNDS AVAILABLE FOR THE PURPOSE OF AWARDING A CONTRACT AND/OR EXPENDING FUNDS FOR THE PURPOSE IDENTIFIED BELOW. THE AMOUNT OF THE CONTRACT AND/OR EXPENDITURE EXCEEDS:   **\$17,500.00**

**PURPOSE: Certified Public Accountant**

ACCOUNT TO BE CHARGED:    *Accounting/01-900-001-8012*

NAME OF PAYEE AND/OR SUCCESSFUL BIDDER:

**Charles J. Fallon, CPA, RMA**

**for the firm Fallon & Company, LLP**

CERTIFICATION DATED: *February 18, 2026*

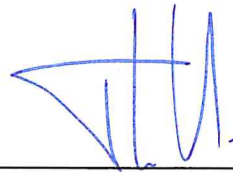

Thomas Roguski, Executive Director

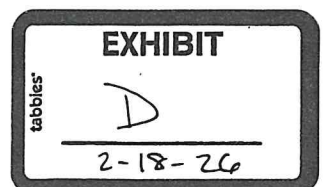

February 5, 2026

Long Branch Sewerage Authority  
150 Joline Avenue  
Long Branch, NJ 07740  
Attn: Thomas Roguski, Executive Director

Re: 2026 Bond Counsel Services

Dear Mr. Roguski:

Enclosed, please find the original proposal to provide Bond Counsel services submitted in response to the Request for Proposals issued by the Long Branch Sewerage Authority.

If you have any questions about this submission or require any additional information, please feel free to call me directly at +1 (201) 546-9200 x 101. Thank you for your consideration.

Very truly yours,

*Jason P. Capizzi*  
Jason P. Capizzi

Enclosures

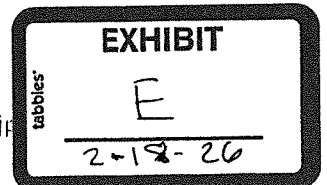

**CERTIFICATION REQUIRED BY THE LOCAL FINANCE BOARD**

I, THOMAS ROGUSKI, EXECUTIVE DIRECTOR OF THE LONG BRANCH SEWERAGE AUTHORITY, COUNTY OF MONMOUTH, HEREBY CERTIFY THAT THERE ARE FUNDS AVAILABLE FOR THE PURPOSE OF AWARDING A CONTRACT AND/OR EXPENDING FUNDS FOR THE PURPOSE IDENTIFIED BELOW. THE AMOUNT OF THE CONTRACT AND/OR EXPENDITURE MAY EXCEED:       **\$17,500.00**

PURPOSE: **Legal Bond Counsel**

ACCOUNT TO BE CHARGED:     *Legal/01-900-001-8008*

NAME OF PAYEE AND/OR SUCCESSFUL BIDDER:

**Jason P. Capizzi, Esq.**

**for the firm of J.P. Capizzi Law Office**

CERTIFICATION DATED: *February 18, 2026*

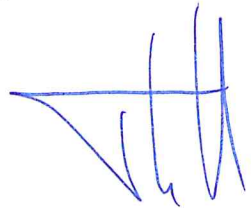

---

Thomas Roguski, Executive Director

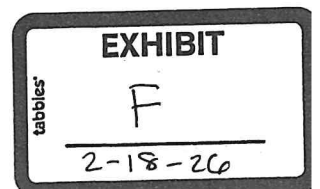

# TRENK ISABEL SIDDIQI & SHAHDANIAN P.C.

---

RESPONSE TO REQUEST FOR PROPOSALS FOR  
PROFESSIONAL SERVICES FOR 2026  
ENVIRONMENTAL ATTORNEY

Issued by:

**LONG BRANCH SEWERAGE AUTHORITY**

*Due Date: February 5, 2026 @ 10:00 AM*

Trenk Isabel Siddiqi & Shahdanian P.C.  
290 W. Mt. Pleasant Avenue, Suite 2370, L  
21 Main Street, Suite 251, Hackensack, New  
973-533-1122 | Fax: 973-533-1111

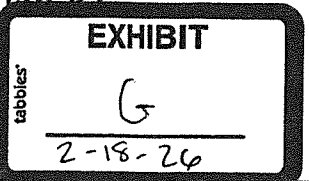

**CERTIFICATION REQUIRED BY THE LOCAL FINANCE BOARD**

I, THOMAS ROGUSKI, EXECUTIVE DIRECTOR OF THE LONG BRANCH SEWERAGE AUTHORITY, COUNTY OF MONMOUTH, HEREBY CERTIFY THAT THERE ARE FUNDS AVAILABLE FOR THE PURPOSE OF AWARDING A CONTRACT AND/OR EXPENDING FUNDS FOR THE PURPOSE IDENTIFIED BELOW. THE AMOUNT OF THE CONTRACT AND/OR EXPENDITURE MAY EXCEED:       **\$17,500.00**

PURPOSE: **Environmental Counsel**

ACCOUNT TO BE CHARGED:    *Legal / 01-900-001-8008*

NAME OF PAYEE AND/OR SUCCESSFUL BIDDER:

**David L. Isabel, Esq.**

**from the firm of Trenk, Isabel, Siddiqi & Shahdanian. PC**

CERTIFICATION DATED: *February 18, 2026*

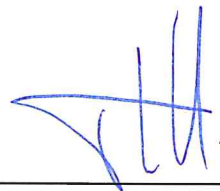

Thomas Roguski, Executive Director

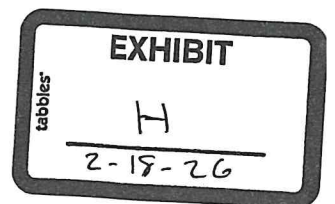

# TAYLOR

LAW GROUP, LLC

430 Mountain Avenue, Suite 103  
New Providence, New Jersey 07974  
(908) 219-7771 Main Office  
(201) 843-5877 Fax  
Email: [ltaylor@taylorlawgroupllc.com](mailto:ltaylor@taylorlawgroupllc.com)

## RESPONSE TO REQUEST FOR PROPOSALS FOR LABOR ATTORNEY/COUNSEL SERVICES FOR THE LONG BRANCH SEWERAGE AUTHORITY

**To:** Authority Office located at the Treatment Plant Site  
150 Joline Avenue  
Long Branch, New Jersey 07740  
Attn: Thomas Roguski, Executive Director

**Due Date:** Thursday, February 5, 2026 at 10:00 A.M.

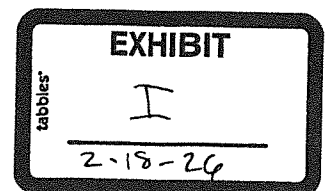

**CERTIFICATION REQUIRED BY THE LOCAL FINANCE BOARD**

I, THOMAS ROGUSKI, EXECUTIVE DIRECTOR OF THE LONG BRANCH SEWERAGE AUTHORITY, COUNTY OF MONMOUTH, HEREBY CERTIFY THAT THERE ARE FUNDS AVAILABLE FOR THE PURPOSE OF AWARDING A CONTRACT AND/OR EXPENDING FUNDS FOR THE PURPOSE IDENTIFIED BELOW. THE AMOUNT OF THE CONTRACT AND/OR EXPENDITURE MAY EXCEED:       **\$17,500.00**

PURPOSE: **Labor Attorney Services**

ACCOUNT TO BE CHARGED:     *Legal/01-900-001-8008*

NAME OF PAYEE AND/OR SUCCESSFUL BIDDER:

**Lester E. Taylor III**

**for the firm Taylor Law Group, LLC**

CERTIFICATION DATED: *February 18, 2026*

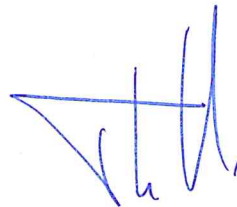

---

Thomas Roguski, Executive Director

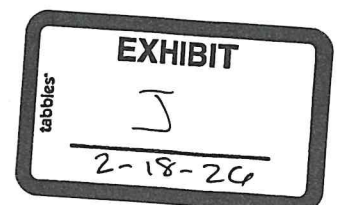

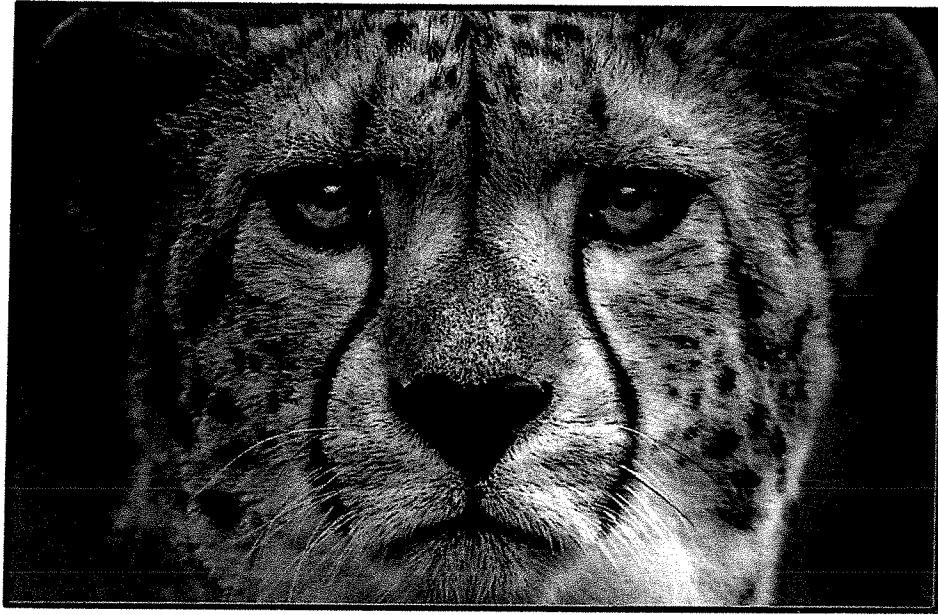

Request for Proposals  
Insurance & Risk  
Management Consultant

For the Long Branch  
Sewerage Authority  
2026

---

Presented by:  
Dominick S. Cinelli  
Senior Vice-President

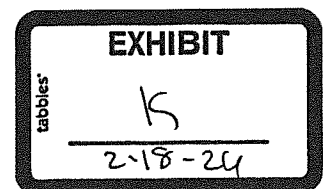

TABLE OF CONTENTS

TAB 1: **Cover Letter**

TAB 2: **Executive Summary**

TAB 3: **Public Sector Expertise**

Brown & Brown COVID19 Resources  
Proactive Response For Weather Related Emergencies  
Sample Client List

TAB 4: **Standard and Property & Casualty Services**

TAB 5: **Meet the Team**

TAB 6: **Licenses and Certifications**

TAB 7: **Fee Proposal**

TAB 8: **Required Forms**



**Mr. Thomas Roguski, Executive Director  
Long Branch Sewerage Authority  
150 Joline Avenue  
Long Branch, NJ 07740**

**Re: Request for Proposals – Insurance & Risk Management Consultant**

Dear Mr. Roguski,

Brown & Brown Metro, LLC is pleased to submit our qualifications for Insurance and Risk Management Consultant. In doing so, we hope to continue to be a valued partner of the Long Branch Sewerage Authority and to continue developing a strong relationship.

Our firm is highly interested in providing Insurance Consultant Services to the Long Branch Sewerage Authority. With expenses rising and increasing budget pressures, expert guidance and management of insurance programs is essential to controlling costs. With Brown & Brown, the Authority will have a partner that can provide these services in a way that does not add risk to the Authority in any way. We are committed to providing the experienced professionals needed to work with you to:

- Coordinate safety and loss control meetings.
- Assist with monitoring of PEOSH training compliance.
- Oversee and manage carrier and JIF relationships;
- Provide guidance with new regulations affecting the Authority's coverage
- Review the Authority's insurance program and make recommendations as appropriate;
- Negotiate renewals and make recommendations on renewals;
- Present to committees, employees or the Authority on renewals and/or other topics as requested;
- Provide key assistance in the day-to-day operations and management of the Authority's insurance program;
- In general guide the Authority in the management of their insurance programs.

As you know, Brown & Brown Metro, LLC is a full-service brokerage and consulting firm specializing in public entity risk management and employee benefit plans. Brown & Brown Insurance is the fifth largest brokerage firm in the United States which provides our firm with a strong market presence with all insurance carriers. Presently, we represent over 350 Public Entities in the State of New Jersey and our staff of over 115 employees stands ready to meet any and all requirements of the Authority.

Our increasing base of experience and expertise has enabled us to offer a broad range of services to municipalities, school districts, government agencies, real estate communities and the general public. Our growing record of accomplishments has helped to establish Brown & Brown Metro, LLC as a leader in our field. We are presently the risk manager and/or insurance broker for many of the public entities in the State of New Jersey that participate in non-traditional insurance programs such as Joint Insurance Funds or self-funded insurance alternatives. We work hand in hand with third party administrators and attorneys in managing these programs.

Over the past several years, Brown & Brown Metro, LLC has provided risk management consultant services to the Somerset Raritan Sewerage Authority, Rockaway Valley Sewerage Authority, North Bergen MUA, and Kearny MUA, among others. We are very familiar with their coverages and procedures and fully understand the exposure and risks of each of the clients that we represent. We will provide our Safety & Loss Control procedures that have proven to be a successful tool in reducing the frequency of Workers' Compensation claims. In addition, Brown and Brown Metro, LLC personnel will attend all required meetings as well as all appropriate meetings of the Joint Insurance Funds.

The combination of our experience, our marketplace position and our tireless attention to detail make us a powerful ally for any employer, particularly a public entity. We believe we will prove to be a valuable asset to the Authority in these difficult financial times.

## KEY DIFFERENTIATORS

Any broker can say they are "different", but can they prove it?



### ENGAGEMENT

Giving you more control, more evidence, and more options



### PROACTIVE SERVICE

Our collective success is earned by creating the perfect solution for you



### BENCHMARKING

Utilizing advanced analytics to quantify the impact on your business

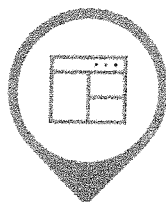

### SPECIALIZATION

Valuing depth of industry/product knowledge to create the best results



### INNOVATIVE SOLUTIONS

Generating evidence-based solutions to lower your risk

We thank you for the opportunity to again provide our qualifications.

We look forward to the opportunity to discuss our qualifications at your convenience.

Sincerely,

**Dominick S. Cinelli, MBA**  
**Senior Vice President**  
**Brown & Brown Metro, LLC.**  
56 Livingston Ave.  
Roseland, NJ 07068

**CERTIFICATION REQUIRED BY THE LOCAL FINANCE BOARD**

I, THOMAS ROGUSKI, EXECUTIVE DIRECTOR OF THE LONG BRANCH SEWERAGE AUTHORITY, COUNTY OF MONMOUTH, HEREBY CERTIFY THAT THERE ARE FUNDS AVAILABLE FOR THE PURPOSE OF AWARDING A CONTRACT AND/OR EXPENDING FUNDS FOR THE PURPOSE IDENTIFIED BELOW. THE AMOUNT OF THE CONTRACT AND/OR EXPENDITURE EXCEEDS:   **\$17,500.00**

**PURPOSE: Insurance Consultant**

**ACCOUNT TO BE CHARGED:   *Insurance/ 01-900-001-8500***

**NAME OF PAYEE AND/OR SUCCESSFUL BIDDER:**

**Dominic S. Cinelli, MBA**

**for the firm of Brown & Brown Metro, LLC**

**CERTIFICATION DATED: *February 18, 2026***

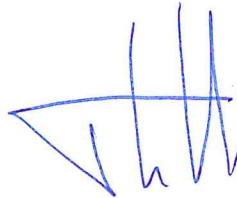

---

Thomas Roguski, Executive Director

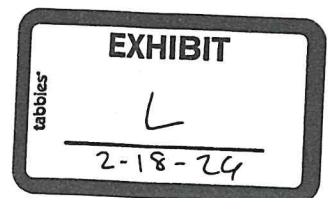

101 Crawfords Corner Road, Suite 3400  
Holmdel, New Jersey 07733  
Main: 877 627 3772



Engineering  
& Design

February 5, 2026

Mr. Thomas Roguski, Executive Director  
Long Branch Sewerage Authority  
150 Joline Avenue  
Long Branch, NJ 07740

RE: Request for Proposals for Professional Services for 2026  
Authority Consulting Engineer  
Colliers Engineering & Design Proposal No, 26000331P

Dear Mr. Roguski,

Colliers Engineering & Design, Inc. is pleased to submit one original of our Proposal for the Long Branch Sewerage Authority. Our submission provides an overview of the staff, technical expertise, and the wastewater municipal and authority experience of the firm. Colliers Engineering & Design has been providing wastewater treatment and collection system planning, design, construction administration, and inspection services to municipalities, utility authorities, private utilities, and private industry since 1984.

It is our goal to provide the Long Branch Sewerage Authority with the utmost level of professional services. Having served the Authority as Consulting Engineer since 1992, Colliers Engineering & Design has unique knowledge of the Authority's engineering requirements and of ongoing engineering matters and procedures. We have the experience and qualified staff necessary to ensure that projects are completed on time and within budget. Our Wastewater Department personnel work out of our Corporate Headquarters located just off the Parkway in the Township of Holmdel.

John J. McKelvey, PE, will serve as Engineer-in-Charge and Client Contact and will attend the Authority's meetings. He has been serving in this role during the past year and will be the best qualified person to continue. Mr. McKelvey has over 40 years of extensive experience in the water and wastewater engineering field. This experience included managing and planning projects, preparation of plans and specifications, permit applications, contract administration, and oversight of construction inspection. He has extensive experience in design of sewer and water utility projects, pump stations, and wastewater treatment plant upgrades. He also has experience with infiltration/inflow evaluations including flow metering, physical investigation, and preparation of rehabilitation plans.

On behalf of Colliers Engineering & Design, I would like to thank you in advance for your time and consideration. If there are any questions or further information is required, please feel free to contact me by phone at 732 704 5408 or by email at [jordan.volk@collierseng.com](mailto:jordan.volk@collierseng.com).

Sincerely,

Colliers Engineering & Design, Inc.

Jordan R. Volk, PE, PMP  
Principal Associate | Regional Discipline Leader

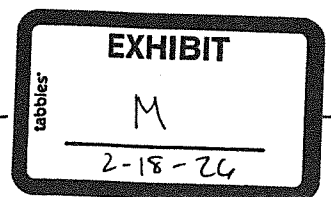

**CERTIFICATION REQUIRED BY THE LOCAL FINANCE BOARD**

I, THOMAS ROGUSKI, EXECUTIVE DIRECTOR OF THE LONG BRANCH SEWERAGE AUTHORITY, COUNTY OF MONMOUTH, HEREBY CERTIFY THAT THERE ARE FUNDS AVAILABLE FOR THE PURPOSE OF AWARDING A CONTRACT AND/OR EXPENDING FUNDS FOR THE PURPOSE IDENTIFIED BELOW. THE AMOUNT OF THE CONTRACT AND/OR EXPENDITURE EXCEEDS:    **\$17,500.00**

**PURPOSE: Professional Engineering Services**

ACCOUNT TO BE CHARGED:    *Engineering/ 01-900-001-8001*

NAME OF PAYEE AND/OR SUCCESSFUL BIDDER:

**Jordan R. Volk, P.E., PMP**

**for the firm Colliers Engineering and Design, Inc.**

CERTIFICATION DATED: *February 18, 2026*

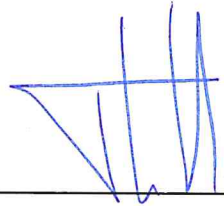

Thomas Roguski, Executive Director

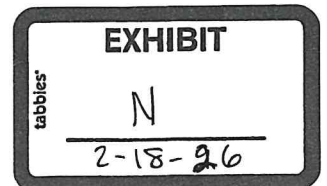



732-785-0006 Option 1



www.safenetsol.com



support@safenetsol.com



**SAFENET**  
SOLUTIONS

SafeNet Solutions, LLC.  
1 Executive Drive, Door J  
Tinton Falls, NJ 07701

Mr. Thomas Roguski, PE, CME  
Executive Director  
Long Branch Sewerage Authority  
150 Joline Avenue  
Long Branch, NJ 07740

Dear Mr. Thomas Roguski:

Thank you for the opportunity to continue servicing the Sewerage Authority's IT needs.

Current technicians who will be providing IT Support include:

Scott Thompson – 21 Years Tenure

Emmanuel Tejuosho – 5 Years Experience

Frank Rivotti – 4 Years Experience

David Bressman – 6 Years Experience

Josuas Alcidas – 2 Years Experience

Stephen Patrick – 26 Years Experience

Enclosed please find a copy of the required documents.

SafeNet has provided IT Solutions to the Authority since 2009. We look forward to continuing this successful partnership and assisting in the future maintenance of your systems and end user support.

Sincerely,

Scott Thompson  
Owner, SafeNet Solutions, LLC.

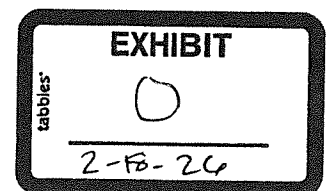

**CERTIFICATION REQUIRED BY THE LOCAL FINANCE BOARD**

I, THOMAS ROGUSKI, EXECUTIVE DIRECTOR OF THE LONG BRANCH SEWERAGE AUTHORITY, COUNTY OF MONMOUTH, HEREBY CERTIFY THAT THERE ARE FUNDS AVAILABLE FOR THE PURPOSE OF AWARDING A CONTRACT AND/OR EXPENDING FUNDS FOR THE PURPOSE IDENTIFIED BELOW. THE AMOUNT OF THE CONTRACT AND/OR EXPENDITURE MAY EXCEED:       **\$17,500.00**

PURPOSE: **Information (IT) Consultant**

ACCOUNT TO BE CHARGED:     ***Computer Maintenance/ 01-900-001-8401***

NAME OF PAYEE AND/OR SUCCESSFUL BIDDER:

**Scott Thompson,**

**for the firm of SafeNet Solutions, LLC.**

CERTIFICATION DATED: ***February 18, 2026***

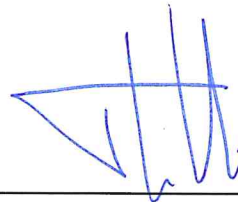

Thomas Roguski, Executive Director

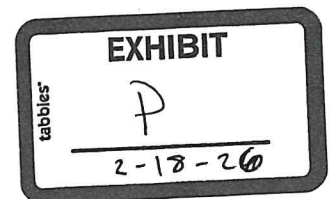

101 Crawfords Corner Road, Suite 3400  
Holmdel, New Jersey 07733  
Main: 877 627 3772

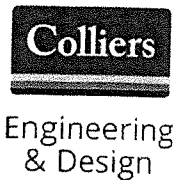

February 5, 2026

Mr. Thomas Roguski, Executive Director  
Long Branch Sewerage Authority  
150 Joline Avenue  
Long Branch, NJ 07740

RE: Request for Proposals for Professional Services for 2026  
Special/Capital Projects Engineers  
Colliers Engineering & Design Proposal No. 26000331P

Dear Mr. Roguski,

Colliers Engineering & Design, Inc. is pleased to submit one original of our Proposal for the Long Branch Sewerage Authority. Our submission provides an overview of the staff, technical expertise, and the wastewater municipal and authority experience of the firm. Colliers Engineering & Design has been providing wastewater treatment and collection system planning, design, construction administration, and inspection services to municipalities, utility authorities, private utilities, and private industry since 1984.

It is our goal to provide the Long Branch Sewerage Authority with the utmost level of professional services. Having served the Authority as Consulting Engineer since 1992, Colliers Engineering & Design has unique knowledge of the Authority's engineering requirements and of ongoing engineering matters and procedures. We have the experience and qualified staff necessary to ensure that projects are completed on time and within budget. Our Wastewater Department personnel work out of our Corporate Headquarters located just off the Parkway in the Township of Holmdel.

John J. McKelvey, PE, will serve as Engineer-in-Charge and Client Contact and will attend the Authority's meetings. He has been serving in this role during the past year and will be the best qualified person to continue. Mr. McKelvey has over 40 years of extensive experience in the water and wastewater engineering field. This experience included managing and planning projects, preparation of plans and specifications, permit applications, contract administration, and oversight of construction inspection. He has extensive experience in design of sewer and water utility projects, pump stations, and wastewater treatment plant upgrades. He also has experience with infiltration/inflow evaluations including flow metering, physical investigation, and preparation of rehabilitation plans.

On behalf of Colliers Engineering & Design, I would like to thank you in advance for your time and consideration. If there are any questions or further information is required, please feel free to contact me by phone at 732 704 5408 or by email at [jordan.volk@collierseng.com](mailto:jordan.volk@collierseng.com).

Sincerely,

Colliers Engineering & Design, Inc.

A handwritten signature in black ink, appearing to read "Jordan R. Volk".

Jordan R. Volk, PE, PMP  
Principal Associate | Regional Discipline Leader

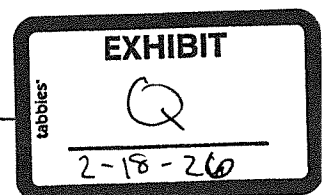



**REMINGTON  
& VERNICK  
ENGINEERS**

429 Route 79, Suite 21  
Morganville, NJ 07751  
O: (732) 955-8000  
F: (732) 591-2815

February 3, 2026

Thomas Roguski, Executive Director  
Long Branch Sewerage Authority  
150 Joline Avenue  
Long Branch, New Jersey 07740

**RE: Request for Proposal to serve as Special/Capital Projects Engineers, 2026  
Long Branch Sewerage Authority, NJ**

Dear Mr. Roguski:

Remington & Vernick Engineers (RVE) is pleased to submit our qualifications to continue to serve as Special/Capital Projects Engineers to the Long Branch Sewerage Authority (Authority). This response has been prepared in accordance with the requirements outlined in the Request for Proposals (RFP) and our many years of experience serving the Authority.

Our support of utility clients includes design, planning and construction services for infrastructure/capital improvements; environmental remediation; utilities collection; treatment and design; government and public works facility additions and renovations; park and recreation improvements; redevelopment and master planning projects. We have experience serving all facets of utility engineering and planning for urban and rural communities, large and small, with an emphasis on understanding the Authority's needs and vision. Below are some factors that set RVE apart from competing firms:

- A skilled and efficient team of engineers, led by **Stephanie Cuthbert, PE, CME, Executive Vice President** and **James Oris, PE, PP, CME, CFM**, both with multiple decades of experience.
- A firm providing comprehensive services, including wastewater conveyance system modeling, pumping station upgrades, trenchless sewer rehabilitation, flow metering and I/I evaluations.
- A local office in Morganville, NJ, allowing us to quickly provide on-site services as needed.

We look forward to the opportunity to continue to serve the Authority under this contract. Should you have any questions or require additional information, please contact Mr. Oris in our Marlboro Township office at 732-955-8000 or via email at [James.Oris@rve.com](mailto:James.Oris@rve.com).

Sincerely,

Leonard A. Faiola, PE, PP, CME  
President & CEO

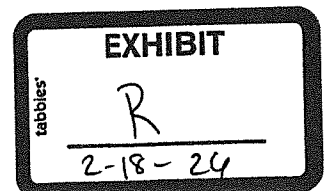



**Consulting & Municipal  
ENGINEERS**  
A Subsidiary of Artheon, Inc.

February 5, 2026

Long Branch Sewerage Authority  
150 Joline Avenue  
Long Branch, NJ 07740

Attn: Mr. Thomas Roguski, Executive Director

**Re: Long Branch Sewerage Authority  
Request for Proposals for Professional Services for 2026  
Special / Capital Projects Engineer  
CME File No.: 115.LB2026A.P00**

In response to your Request for Proposals (RFP), we wish to thank you for your consideration of CME Associates for providing **Special / Capital Projects Engineer** services to the Long Branch Sewerage Authority (Authority). As the content of our submittal demonstrates, our Firm and Staff possess the resources, experience, and expertise necessary to represent the Authority in a professional, efficient and responsive manner. Accordingly, please find enclosed one (1) printed original of our response to the Authority's RFP.

Founded in 1983, CME Associates is a multi-disciplined engineering Firm dedicated to delivering public sector infrastructure solutions to public and private Clients throughout New Jersey.

Professional excellence is the cornerstone of our success - we recognize the importance of technical expertise and focus on innovative ways to deliver cost-effective and technically-sound services in a timely manner. Throughout our forty-three-year history, we have established relationships and lines of communication with municipal, state and federal regulators that enable us to become a value-added partner to our Clients.

CME Associates takes great pride in our commitment to personal service, and our ability to successfully address your interests. We possess a high degree of familiarity with the duties and obligations associated with providing Consulting Engineering services and feel confident in our Firm's ability to address the concerns of the Authority in accordance with the scope of services included in the Request for Proposals.

We are pleased to present **Keith Chiaravallo, P.E., C.M.E., and a Senior Vice President**, as the Key Contact for Authority Projects. He has over 30 years of experience and has continuously represented numerous New Jersey Authorities and Municipalities. Mr. Chiaravallo is a licensed New Jersey Professional Engineer and a Certified Municipal Engineer (CME). His detailed resume is included in our submission under *Section 2 | Resumes of Key Staff*.

A Team of individuals with directly relevant experience and the technical knowledge to achieve the Authority's objectives will support Mr. Chiaravallo. The Project Team members will be selected based upon their areas of experience and similar experience that matches your Project needs. We have provided resumes of key personnel, as

CONSULTING AND MUNICIPAL ENGINEERS, LLC • A SUBSIDIARY OF ARTHEON, INC.

NJ CERTIFICATE OF AUTHORIZATION NO. 24GA28359000 (CME)

NJ CERTIFICATE OF AUTHORIZATION NO. 24GA28412500 (ARTHEON)

Barnegat • Berlin • Camden • Cape May Court House • East Brunswick • Howell • Parlin

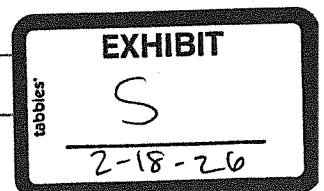



**Consulting & Municipal  
ENGINEERS**  
A Subsidiary of Artheon, Inc.

Mr. Thomas Roguski, Executive Director  
Long Branch Sewerage Authority  
Re: RFP for Professional Services  
Special / Capital Projects Engineer

February 5, 2026  
Our File No. 115.LB2026A.P00  
Page 2

well as representative Projects indicating the individuals' and Firm's experience in the wastewater field. In addition, CME Associates is familiar with the City of Long Branch due to our roles with the City Engineer's Office and Planning Board.

We would welcome the opportunity to serve the Authority and its Professionals and Staff. All the forms as required by the Authority have been completed, signed and sealed, as applicable, in our qualifications statement. We trust the information contained herein addresses your qualification requirements.

Should you require additional information, or should you have any questions concerning the above, we would be pleased to discuss them with you in more detail and provide clarification as necessary.

Very truly yours,

**CME Associates**

Keith Chiaravallo, P.E., C.M.E.  
Senior Vice President, Water/Wastewater

February 5, 2026

Long Branch Sewerage Authority  
Attn: Mr. Thomas Roguski, PE, CME, Executive Director  
150 Joline Avenue  
Long Branch, NJ 07740

Re: Request for Proposals for Professional Services for 2026 – Special/Capital Projects Engineer

Dear Mr. Roguski:

Pursuant to the Long Branch Sewerage Authority's (LBSA) Request for Proposals for Professional Services for 2026 – Special/Capital Projects Engineer, Van Cleef Engineering Associates, LLC (Van Cleef) is pleased to submit our Proposal for review and consideration.

As a multi-disciplined firm of engineers, landscape architects, bridge and dam engineers, certified inspectors and land surveyors, Van Cleef provides expertise in all of the major areas of water/wastewater engineering, civil engineering and land surveying. Our firm has over 225 employees in nine (9) regional offices strategically located throughout New Jersey and eastern Pennsylvania. We are focused on building offices and long-term relationships in concentrated regions which allows us to bring a unique understanding of the local codes, regulations, and processes to every project. As a WBE-certified company, we adhere to the highest standards of business practices while championing opportunities for women in entrepreneurship and leadership roles. This certification underscores our credibility, reliability, and capability to meet the diverse needs of our clients and partners.

It is proposed that I, Mark A. Bean, PE, CGP, LEED AP, FIGP will serve as Project Principal and act as primary point of contact. I bring more than thirty-four (34) years of diverse facility-intensive planning, design, and construction management experience and have extensive expertise in wastewater treatment, in the design and construction of wastewater infrastructure, in the operations and maintenance of wastewater facilities and collection systems, and in efficient and effective planning for long-term capitalization and asset management to ensure a sustainable future for the Authority and its assets.

LBSA is among the many Authorities I have had the pleasure to serve in recent years. My direct experience with the Authority over the past 4-5 years includes evaluation of many of your key plant processes as well as significant input into the design and construction of recent capital projects, both within the treatment facility and in your pumping and collection system network. I value the professional and effective working relationship we have shared over the years, and I have worked to be viewed as a trusted and practical partner by your Plant Superintendent and your operations staff. I am intimately familiar with the responsibilities of an Authority Engineer, as well as the productive working relationships they must forge in supporting both the mission and the daily workings of the Authority. It would be a distinct honor for myself and the entire Van Cleef team to continue to serve the Authority.

**OFFICE LOCATIONS**

[www.vancleefengineering.com](http://www.vancleefengineering.com)

Hillsborough, NJ  
908-359-8291

Mt. Arlington, NJ  
862-284-1100

Phillipsburg, NJ  
908-454-3080

Doylestown, PA  
215-345-1876

Pottstown, PA  
610-323-4040

Hamilton, NJ  
609-689-1100

Toms River, NJ  
732-573-0490

Freehold, NJ  
732-303-8700

Bethlehem, PA  
610-332-1772

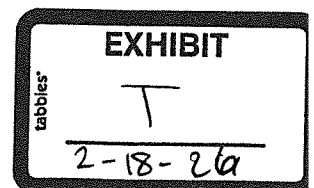

I will be supported by an exceptional team of professionals. We have been the water and wastewater engineers for dozens of Municipal and Regional Utility Authorities and municipalities and the water and wastewater design engineers for numerous land developers. Current Van Cleef staff members have extensive experience assisting Municipalities and Authorities with the design, construction and operation of numerous water and wastewater infrastructure projects including upgrades, rehabilitations, and expansions. Van Cleef has considerable experience in facility inspections, asset management, and capital planning, as well as both fostering growth and protecting an Authority's interests through the review of developer applications. Our capabilities also include assisting with funding applications such as the NJ Infrastructure Bank (I-Bank) and the USDA loan & grant applications through the U.S. Department of Agriculture. Van Cleef's wastewater professionals are some of the best in the business.

Please note that all required documents listed in this solicitation are included in this submission, including key staff and qualifications, areas of practice, experience and reputation, staff summaries, organizational chart, resumes, ability to provide timely services, and required business documents.

We appreciate the opportunity to submit this Statement of Qualifications and look forward to working with the Authority. Should you have any questions concerning this submission, please do not hesitate to contact me please do not hesitate to contact me directly at any time via phone at (732) 485-8594 or via email to [mbean@vancleefengineering.com](mailto:mbean@vancleefengineering.com).

Very truly yours,



Mark A. Bean, PE, CGP, LEED AP, FIGP  
Vice President, Water/Wastewater

# RESPONSE TO REQUEST FOR PROPOSALS (“RFP”)

## SPECIAL/CAPITAL PROJECTS ENGINEERS

Thomas Roguski, Executive Director  
Long Branch Sewerage Authority  
Authority Office at the Treatment Plant Site  
150 Joline Avenue, Long Branch, NJ 07740

# LBSA

**LONG BRANCH SEWERAGE AUTHORITY**

ORIGINAL

Submitted by:

**PEi** PRESTIGE  
ENVIRONMENTAL  
Inc.

Innovation...because your property matters

*Since 1993*

Girish Mehta, P.E., LSRP  
220 Davidson Avenue, Suite 307  
Somerset, New Jersey 08873  
T. 908-757-9700 C. 908-875-9854  
girish.mehta@prestige-environmental.com

Due Date: February 5, 2026 at 10:00AM

EXHIBIT

tabbles

U

2-18-26

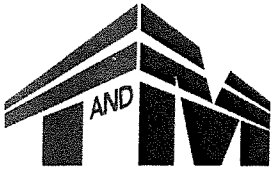

YOUR GOALS. OUR MISSION.

LBSA 26010

February 5, 2026

Thomas Roguski  
Executive Director  
Long Branch Sewerage Authority  
150 Joline Avenue  
Long Branch, NJ 07740

RE: PROPOSAL FOR SPECIAL/CAPITAL PROJECTS ENGINEERS IN 2026

Dear Mr. Roguski,

For nearly 60 years, **T&M Associates (T&M)** has supported sewerage authorities across the region, helping them navigate the evolving landscape of public sector challenges. Our multidisciplinary team of engineers, environmental scientists, planners and other specialists, takes a proactive, solutions-driven approach to support local governments achieve their goals efficiently and sustainably.

We understand the pressures municipalities face: adapting to new regulations, securing funding and meeting community expectations. That's why we offer more than just technical expertise, we provide strategic insight, responsive service and a deep understanding of local priorities. Our long-standing relationships with public sector clients are built on trust, collaboration and a shared commitment to improving the communities we serve.

As a leading mid-sized firm with the capabilities of a large organization, we offer a unique blend of personalized service and technical depth. With more than 370 employees holding over 250 professional licenses, we have the in-house capabilities to meet the needs of the Authority. Our flexible approach allows us to tailor solutions to your specific requirements while drawing on a diverse team of professionals to deliver innovative, cost-effective results.

We are pleased to submit our proposal to serve as Special/Capital Projects Engineers in 2026.

T&M has extensive experience working with sewerage authorities. We have been involved in operational assistance and evaluation, financial and budgeting issues, capital planning, NJPDES compliance and permit renewals, the development and updating of wastewater management plans, sludge management issues and development reviews. We have also provided planning, design and construction engineering for numerous sewerage projects. Our presence in Middletown also gives us a strong familiarity with the region and the infrastructure that supports it.

We are excited about the opportunity to work with you in the upcoming year. If you need additional information or have any questions after reviewing our submittal, please don't hesitate to contact me at 732.865.9605 or via email at [NRotonda@tandmassociates.com](mailto:NRotonda@tandmassociates.com).

Very truly yours,

Nicholas Rotonda, PE, PP, CME  
Senior Client Manager, Water

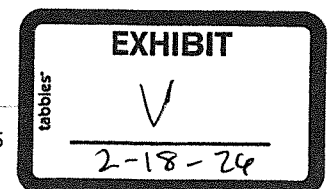



# REQUEST FOR PROPOSAL

---



## REQUEST FOR PROPOSALS FOR PROFESSIONAL SERVICES FOR 2025 SPECIAL/CAPITAL PROJECTS ENGINEERS

DATE: February 5, 2026

KEYSTONE ENGINEERING GROUP, INC.  
3836 QUAKERBRIDGE ROAD, SUITE 103  
HAMILTON, NJ 08619

William F. Bleiler, P.E., LEED AP  
609-512-5802  
wbleiler@kegi.net

Keystone Corporate Headquarters  
590 Lancaster Ave, Suite 200  
Frazer, PA 19355

(610) 407-4100  
sales@kegi.net

Keystone Branch  
Lewes, DE | S  
Hamilton, NJ | C

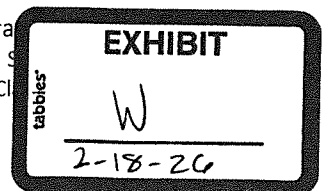

# FPA

**FRENCH & PARRELLO  
ASSOCIATES**

1800 Route 34, Suite 101  
Wall Township, New Jersey 07719  
T: 732.312.9800  
F: 732.312.9801  
fpaengineers.com

February 5, 2026

Mr. Thomas Roguski, Executive Director  
Long Branch Sewerage Authority  
150 Joline Avenue  
Long Branch, New Jersey 07740

RE: Proposal for Professional Services for 2026  
**Special / Capital Projects Engineers Pool 2026**  
FPA No. 19810.T03

Dear Mr. Roguski:

The Long Branch Sewerage Authority (Authority) is committed to maintaining the health, safety, wellbeing and improving the quality of life for its customers within the Authority's service area. The Authority's dedication to operating and maintaining its wastewater collection, conveyance, treatment and outfall system in a diligent and fiscally responsible manner is apparent. However, in these challenging times it has become more difficult to do more with less. As such the Authority is soliciting proposals and statements of qualification from consulting engineering firms to develop a prequalified Special / Capital Projects Engineers Pool for 2026 to help the Authority ensure their continued success.

**French & Parrello Associates (FPA)** is pleased to submit our proposal and statement of qualifications for consideration to be included in the Special / Capital Projects Engineers Pool for 2026. FPA has prepared this submittal in accordance with the Authority's Request for Proposals for Professional Services for 2026.

FPA is a multi-discipline engineering firm, employing over 250 professionals in six offices with corporate headquarters in Wall, NJ. Through its principals and staff, the firm has established a reputation of technical excellence and responsiveness on diverse and complex projects. Backed by our expertise and wide range of services, we feel that our commitment to client satisfaction has made us a leader in engineering design from project inception to closeout.

FPA will manage this contract from our Wall, NJ office. The close proximity of our staff allows us to be responsive to the needs of the Authority and to help address engineering or environmental challenges that may arise in a diligent and timely manner. We will be readily available to accommodate attendance at meetings requested by the Authority.

On behalf of FPA, I thank you for the opportunity to provide consulting engineering services to the Authority in 2026.

Respectfully Submitted,  
**FRENCH & PARRELLO ASSOCIATES**

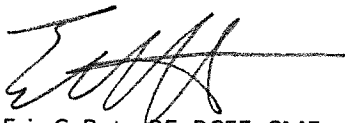

Eric C. Betz, PE, BCEE, CME  
Vice President, Director of Infrastructure  
[Eric.Betz@fpaengineers.com](mailto:Eric.Betz@fpaengineers.com)

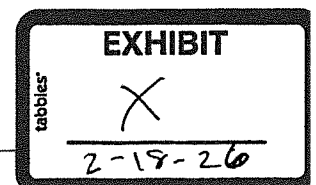

**CERTIFICATION REQUIRED BY THE LOCAL FINANCE BOARD**

I, THOMAS ROGUSKI, EXECUTIVE DIRECTOR OF THE LONG BRANCH SEWERAGE AUTHORITY, COUNTY OF MONMOUTH, HEREBY CERTIFY THAT THERE ARE FUNDS AVAILABLE FOR THE PURPOSE OF AWARDING A CONTRACT AND/OR EXPENDING FUNDS FOR THE PURPOSE IDENTIFIED BELOW. THE AMOUNT OF THE CONTRACT AND/OR EXPENDITURE MAY EXCEED: **\$17,500.00**

PURPOSE: **2026 Special/Capital Project Engineers**

ACCOUNT TO BE CHARGED:

**GF -U/R Net Position Reserve for Rate Stabilization 07-700-002-2201 and/or**

**CF – Reserve for Construction Fund 08-500-001-1970**

NAMES OF PAYEE AND/OR SUCESSFUL BIDDERS:

Jordan R. Volk, PE, PMP for the firm of Colliers Engineering & Design, LLC

Leonard A. Faiola, PE, PP, CME for the firm of Remington & Vernick Engineers

Keith Chairavallo, PE, CME for the firm of CME Associates

Mark A. Bean, PE, CGP, LEED-AP, FIGP for the firm of Van Cleef Engineering

Girish Mehta, PE for the firm of Prestige Environmental Inc.

Nicholas Rotonda, PE,PP,CME for the firm of T&M Associates

William F. Bleiler, PE, LEED AP for the firm Keystone Engineering Group, LLC

Eric C. Betz, PE, BCEE, CME for the firm of French & Parello Associates

CERTIFICATION DATED: *February 18, 2026*

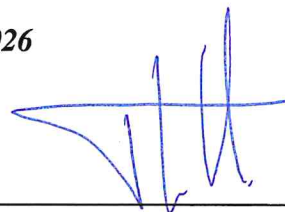

Thomas Roguski, Executive Director

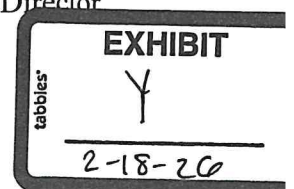

**LONG BRANCH SEWERAGE AUTHORITY**  
**NOTICE OF REGULAR MEETINGS FOR THE YEAR 2026**

NOTICE is hereby given that Regular Meetings of the Long Branch Sewerage Authority for the year 2026 are scheduled to be held in the Conference Room at the Administration Building of the Long Branch Sewerage Authority Treatment Plant, located at 150 Joline Avenue, Long Branch, New Jersey 07740, on dates and times as follows:

Wednesday, March 18, 2026	-	3:00 pm
Wednesday, April 15, 2026	-	5:00 pm
Wednesday, May 20, 2026	-	3:00 pm
Wednesday June 17, 2026	-	3:00 pm
Wednesday, July 15, 2026	-	3:00 pm
Wednesday, August 19, 2026	-	3:00 pm
Wednesday, September 16, 2026	-	3:00 pm
Wednesday, October 21, 2026	-	3:00 pm
Thursday, November 12, 2026	-	3:00 pm
Wednesday, December 16, 2026	-	3:00 pm
Wednesday, January 20, 2027	-	3:00 pm
Wednesday, February 17, 2027	-	3:00 pm

Both in-person and remote attendance options are available.

**FOR IN-PERSON ATTENDANCE:** individuals may attend Regular Meetings in-person in the Conference Room at the Administration Building of the Long Branch Sewerage Authority Treatment Plant, located at 150 Joline Avenue, Long Branch, New Jersey 07740.

**FOR REMOTE ATTENDANCE:** individuals may attend Regular Meetings remotely. For dial-in information, please contact the Long Branch Sewerage Authority at 732-222-0500 or visit the Long Branch Sewerage Authority website at [LBSA.NET](http://LBSA.NET). Note that dial-in information is subject to change month-to-month.

Public comments may be made during Public Participation and the Miscellaneous Suggestions for the Good of the Authority portions of the Regular Meetings, either in-person or remotely. Public comments may also be submitted in advance of the Regular Meetings via email ([troguski@lbsa.net](mailto:troguski@lbsa.net)) or written letter received by 1:00PM of the date of each Regular Meeting.

A full agenda with regularly scheduled items is anticipated at each Regular Meeting. Formal action may be taken at the Regular Meetings by the Board of Commissioners of the Long Branch Sewerage Authority.

Donald S. Riley  
Chairman

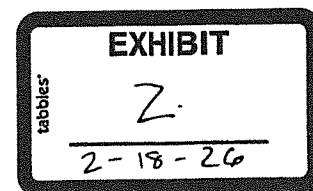

**LONG BRANCH SEWERAGE AUTHORITY  
CASH MANAGEMENT PLAN  
OF LONG BRANCH, IN THE COUNTY OF MONMOUTH, NEW JERSEY**

**I. STATEMENT OF PURPOSE**

This Cash Management Plan (the "Plan") is prepared pursuant to the provisions of N.J.S.A. 40A:5-14 in order to set forth the basis for the deposits ("Deposits") and investment ("Permitted Investments") of certain public funds of the Long Branch Sewerage Authority, pending the use of such funds for the intended purposes. The Plan is intended to assure that all public funds identified herein are deposited in interest bearing Deposits or otherwise invested in Permitted Investments hereinafter referred to. The intent of the Plan is to provide that the decisions made with regard to the Deposits and the Permitted Investments will be done to ensure the safety, the liquidity (regarding its availability for the intended purposes), and the maximum investment return within such limits. The Plan is intended to ensure that any Deposit or Permitted Investment matures within the time period that approximates their prospective need for the funds deposited or invested so that there is not a risk to the market value of such Deposits or Permitted Investments.

**II. IDENTIFICATION OF FUNDS AND ACCOUNTS TO BE COVERED BY THE PLAN**

A. The Plan is intended to cover the deposit and/or investment of the following funds and accounts of the Long Branch Sewerage Authority:

1. FUNDS

LBSA - Revenue Fund  
LBSA - General Fund  
LBSA - Bond Service Fund  
LBSA - Maintenance Reserve Fund  
LBSA - Revenue Bond Fund - 2024

2. DEPOSIT ACCOUNTS

LBSA - Revenue Fund, Collection Account  
LBSA - Revolving Fund, Payroll Checking Account  
LBSA - Revolving Fund, Checking Account  
LBSA - Revolving Fund, EFT Checking Account

B. It is understood that this Plan is not intended to cover certain funds and accounts of the Long Branch Sewerage Authority, which are active escrow accounts, specifically:

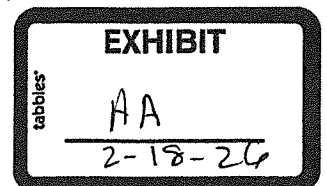

LBSA Treasurer Fund - Developer's Escrow

The above accounts are active as of the date of the adoption of this Plan.

**III. DESIGNATION OF OFFICIAL OF THE LONG BRANCH SEWERAGE AUTHORITY AUTHORIZED TO MAKE DEPOSITS AND INVESTMENTS UNDER THE PLAN**

Given the direct approval by the Board of Commissioners, the Comptroller of the Long Branch Sewerage Authority (the "Designated Official") is hereby authorized and directed to deposit and/or invest the funds referred to in the Plan. Prior to making any such Deposits or any Permitted Investments, such officials of the Long Branch Sewerage Authority are directed to supply to all depositories or any other parties with whom the Deposits or Permitted Investments are made a written copy of this Plan which shall be acknowledged in writing by such parties and a copy of such acknowledgment kept on file with such officials.

**IV. DESIGNATION OF DEPOSITORIES AND TRUSTEE BANKS**

The following banks and financial institutions are hereby designated as official depositories for the Deposit of all public funds referred to in the Plan, including any Certificates of Deposit which are not otherwise invested in Permitted Investments as provided for in this Plan:

Depository Bank: The Bank of New York Mellon  
Depository Bank: Kearny Federal Savings Bank  
Depository Bank: New Jersey Cash Management Fund  
Trustee Bank: The Bank of New York Mellon

All such depositories shall acknowledge in writing receipt of this Plan by sending a copy of such acknowledgment to the Designated Official(s) referred to in Section III above.

**V. AUTHORIZED INVESTMENTS**

- A. Except as otherwise specifically provided herein, the Designated Official is hereby authorized to invest the public funds covered by this Plan, to the extent not held in deposits, in the following Permitted Investments:

- \* Depository Funds must be maintained in interest bearing accounts with certified Government Unit Depository Protection Act banks (GUDPA). Certification must be provided annually by the Official Depository. The Designated Official of the Authority must be notified, in writing, of any GUDPA changes.
- \* Monies in the Funds established under the Resolution may be invested at the Authority's direction in:
  - a) Any direct and general obligation of, or any obligation fully and unconditionally guaranteed by the United States of America.
  - b) Any bond, debenture, note or participation certificate issued by an agency of the following Federal agencies; Export-Import Bank, TVA, FNMA, GNMA, FHA, Federal Financing Bank, Sallie Mae and the U.S. Postal Service.
  - c) Negotiable or non-negotiable CD's issued by any bank, trust company or national banking association in New Jersey or having a capital stock and surplus of more than \$50,000,000.
  - d) Full faith and credit obligations of any State provided such obligations are rated in either of the two highest rating categories by a national recognized bond rating agency.
  - e) Repurchase agreement with any bank, trust company or national banking association with the same provisions as those mentioned in d) above.

B. Notwithstanding the above authorization, the monies on hand in the following funds and accounts shall be further limited as to maturities, specific investments or otherwise as follows:

Only the securities described in section a) above (which are defined as {Government Obligations}) may be used for defeasance or invested Sinking Fund purposes.

**VI. SAFEKEEPING CUSTODY PAYMENT AND ACKNOWLEDGMENT OF RECEIPT OF PLAN**

To the extent that any Deposit or Permitted Investment involves a document or security which is not physically held by the Long Branch Sewerage Authority, then such instrument or security shall be covered by a custodial agreement with an independent third party, which shall be a bank or financial institution in the State of New Jersey. Such institution shall provide for the designation of such investments in the name of the Long Branch Sewerage Authority to assure that there is no unauthorized use of the funds or the Permitted Investments or Deposits. Purchase of any Permitted Investments that involve securities shall be executed by a "delivery versus payment" method to insure that such Permitted Investments are either received by the Long Branch Sewerage Authority or by a third party custodian prior to or upon the release of the Long Branch Sewerage Authority's funds.

To assure that all parties with whom the Long Branch Sewerage Authority deals either by way of Deposits or Permitted Investments are aware of the authority and the limits set forth in this Plan, all such parties shall be supplied with a copy of this Plan in writing and all such parties shall acknowledge the receipt of that Plan in writing, a copy of which shall be on file with the Designated Official(s).

**VII. REPORTING REQUIREMENTS**

On the day of each Regular Monthly Meeting during which this Plan is in effect, the Designated Official(s) referred to in Section III hereof shall supply to the governing body of the Long Branch Sewerage Authority a written report of any Deposits or Permitted Investments made pursuant to this Plan, which shall include, at a minimum, the following information:

- A. The name of any institution holding funds of the Long Branch Sewerage Authority as a Deposit or a Permitted Investment.
- B. The amount of securities or Deposits purchased or sold during the immediately preceding month.
- C. The class or type of securities purchased, or Deposits made.
- D. The book value of such Deposits or Permitted Investments.
- E. The income earned on such Deposits or Permitted Investments during the immediately preceding month.
- F. The fees incurred to undertake such Deposits or Permitted Investments.
- G. The market value of all Deposits or Permitted Investments as of the end of the immediately preceding month.

H. All other information which may be deemed reasonable from time to time by the governing body of the Long Branch Sewerage Authority.

**VIII. DISCLOSURE**

Any official involved in the designation of depositories or in the authorization for investments as permitted pursuant to section 8 of P.L. 1977, c. 396 (C.40A:5-15.1), or any combination of the preceding, or the selection of an entity seeking to sell an investment to the local unit who has a material business or personal relationship with that organization shall disclose that relationship to the governing body of the local unit and to the Local Finance Board or a county or municipal ethics board, as appropriate.

**IX. TERM OF PLAN**

This Plan shall be in effect from February 1, 2026, to January 31, 2027. Attached to this Plan is a resolution of the governing body of the Long Branch Sewerage Authority approving this Plan for such period of time. The Plan may be amended from time to time. To the extent that any amendment is adopted by the Governing Body of the Long Branch Sewerage Authority, the Designated Official is directed to supply copies of the amendments to all of the parties who otherwise have received the copy of the originally approved Plan, which amendment shall be acknowledged in writing in the same manner as the original Plan was so acknowledged.

**X. LISTING OF PLAN RECIPIENTS**

Long Branch Sewerage Authority - Board of Commissioners

The Bank of New York Mellon

Financial Advisor

Bond Counsel

Kearny Federal Savings and its Division of Central Jersey Bank

101 Crawfords Corner Road  
Suite 3400  
Holmdel New Jersey 07733  
Main: 877 627 3772

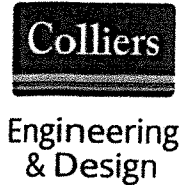

RECEIVED

February 4, 2026

FEB 4 2026

**VIA EMAIL**

L.B. SEWERAGE AUTHORITY

Thomas Roguski, PE, Executive Director  
Long Branch Sewerage Authority  
150 Joline Avenue  
PO Box 270  
Long Branch, New Jersey 07740

Change Order No. 2  
Hoey Pump Station Improvements Project  
Long Branch Sewerage Authority  
City of Long Branch, Monmouth County, New Jersey  
Colliers Engineering & Design Project No. LBS-0330

Dear Mr. Roguski,

We have received Change Order Request No. 2 from Rapid Pump & Meter Service Co., PO Box AY, 285 Straight Street 07509, for NJ 07509, for the Hoey Pump Station Improvements Project. Based upon documents submitted in support of their request and review of the same I recommend approval of Change Order Request No. 2. We have prepared Change Order 2 for review and approval by the Authority and the NJDEP.

Change Order No. 2 consists of the following changes:

1. Modifications to the size and height of the elevated structural platform to accommodate some changes in the final sizes and spacing requirements for the proposed electrical equipment (contract increase);
2. Modifications to the proposed structural grating on the intermediate level of the pump station to facilitate access to the pumps without the need to remove large sections of the grating panels and improve efficiency and safety of maintenance operations (contract increase); and,
3. Change in material for the pump suction elbows to fabricated steel (contract decrease).

Change Order No. 2 results in an overall increase to the contract in the amount of \$22,204.68. The original contract amount was \$1,738,000.00 and the revised contract total amount is \$1,760,204.68.

Attached, please find the following documents for review and approval:

1. NJDEP Change Order No. 2;
2. Construction Bulletin 1 detailing the changes to the size and height of the elevated platform; and,
3. Sketch detailing the changes to structural grating.

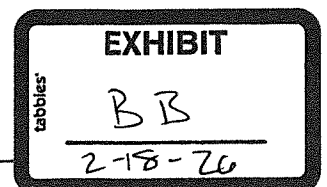

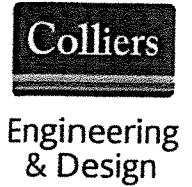

Should you have any questions or require additional information, please do not hesitate to contact me directly.

Sincerely,

Colliers Engineering & Design, Inc.

A handwritten signature in black ink that reads "John J. McKelvey".

John J. McKelvey, P.E.  
Senior Project Manager

JJM/dji

Enclosure

cc: Bruce Bradford, Colliers Engineering & Design (via email)  
Dominic Ierardi, Colliers Engineering & Design, Inc. (via email)

r:\projects\l-lbs\lbs0330\construction\change orders\change order 2\260204\_jjm\_roguski\_co2.docx

**CONTRACT MODIFICATION PROPOSAL AND ACCEPTANCE**

1. ISSUING OFFICE <b>Long Branch Sewerage Authority</b>	2. PROJECT NO. <b>S340336-11</b>	3. CONTRACT NO. <b>LBS0330</b>	4. MODIFICATION NO. <b>2</b>
5. TO (CONTRACTOR) Rapid Pump & Meter Service Co., LLC PO Box AY/285 Straight Street Paterson, NJ 07509		6. PROJECT LOCATION AND DESCRIPTION Hoey Pump Station Improvements Project	

7. A proposal is required for making the hereinafter described change in accordance with specification and drawing revisions cited herein or listed in attachment hereto. Submit your proposal in space indicated on page 2, attach detailed breakdown of prime and sub-contract costs (See the clause of this contract entitled, "Changes". DO NOT start work under this proposed change until you receive a copy signed by the Contracting Officer or a directive to proceed).

\_\_\_\_\_  
 Date Thomas Roguski, Executive Director \_\_\_\_\_  
Type Name and Title Signature

8. DESCRIPTION OF CHANGE: Pursuant to the clause of this contract covering changes, the contractor shall furnish all labor and material, and all work and equipment necessary to accomplish the following described work:

Proposed increase in size to the elevated equipment platform to accommodate final sizes of electrical equipment.

As a result of the above, the contract price is revised as follows:

<u>ITEM NO.</u>	<u>ITEM DESCRIPTION</u>	<u>UNIT PRICE</u>	<u>EST. QTY.</u>	<u>TOTAL COST</u>
S-2	Increase in size to elevated equipment platform.	\$16,490.68	1 LS	\$16,490.68
S-3	Removable grating sections modifications/	\$6,995.00	1 LS	\$6,995.00
S-4	Change in material to fabricated steel suction elbows	-\$1,281.00	1 LS	-\$1,281.00

Contractor agrees that the time extension and cost of this Contract Modification (Change Order) shall be full and complete compensation to the Contractor for the Work described herein and, as such, Contractor, its officers, employees, successors and assigns, hereby releases the Owner, its Board Members, officers, employees and consultants of any and all claims, including, but not limited to, disruption, delay, loss of productivity, idle time for persons and equipment, home office overhead, extended or disrupted performance, additional mobilizations, re-mobilizations, indirect or impact claims, loss of profit, together with any other damages, that relate in any way to the Work described in this Contract Modification (Change Order).

**TOTAL COST OF THIS MODIFICATION:** \$ 22,204.68

The contract time is hereby: increased  decreased  or remains the same  by 0 calendar days as a result of this modification.

The foregoing modifications are hereby accepted:

CONTRACTOR	OWNER	(NJPE SEAL)	ENGINEER
BY: <u>Paul Kearney</u>	BY: <u>Thomas Roguski</u>	BY: _____	BY: <u>John McKelvey, PE</u>
DATE: _____	DATE: _____	DATE: _____	

APPROVAL: \_\_\_\_\_  
STATE OF NEW JERSEY DATE

**CONTRACT MODIFICATION PROPOSAL AND ACCEPTANCE**

9. ISSUING OFFICE  <b>Long Branch Sewerage Authority</b>	10. PROJECT NO.  <b>S340336-11</b>	11. CONTRACT NO.  <b>LBS0330</b>	12. MODIFICATION NO.  <b>2</b>
13. CONTRACTOR'S PROPOSAL – CHANGE IN CONTRACT PRICE (Detailed breakdown, attach additional sheets as necessary)			
(Proposed)			
See attached Change Order Recommendation by John McKelvey of Colliers Engineering & Design, dated February 4, 2026			
The Change Order is in agreement with Rapid Pump & Meter Service Co, Long Branch Sewerage Authority, and Colliers Engineering & Design, Inc..			
NET INCREASE \$ <u>22,204.68</u>		NET DECREASE \$ <u>0.00</u>	
CALENDER DAYS INCREASE <u>0</u> DAYS			
DATE:	TYPE NAME AND TITLE:  Rapid Pump & Meter Service Co.	SIGNATURE:	

**CONTRACT MODIFICATION PROPOSAL AND ACCEPTANCE**

14. ISSUING OFFICE & PROJECT NO.  <p style="text-align: center;"><b>Long Branch Sewerage Authority S340336-11</b></p>	15. CONTRACT NO.  <p style="text-align: center;"><b>LBS-0330</b></p>	16. MODIFICATION NO.  <p style="text-align: center;"><b>2</b></p>
17. ORIGINAL CONTRACT BID PRICE ..... \$ <u>1,738,000.00</u> TOTAL OF PREVIOUS CHANGE ORDERS ..... \$ == TOTAL CONTRACT COST INCLUDING CHANGE ORDERS ... \$ <u>1,760,204.68</u>		
18. NECESSITY FOR CHANGE AND REASON FOR OMISSION FROM PLANS AND SPECIFICATIONS:  <p>See attached Change Order Recommendation by John McKelvey of Colliers Engineering &amp; Design, dated February 4, 2026.</p>		
19. OTHER IMPACTS RESULTANT OF THIS CHANGE:  <p>None.</p>		
20. RESUME OF NEGOTIATIONS OR RECOMMENDATIONS (Loanee's Representative) :  <p>See attached Change Order Recommendation by John McKelvey of Colliers Engineering &amp; Design, dated February 4, 2026.</p>		
DATE:	TYPE NAME AND TITLE OF LOANEE'S REPRESENTATIVE:  <p style="text-align: center;">Thomas Roguski, PE Long Branch Sewerage Authority</p>	SIGNATURE:

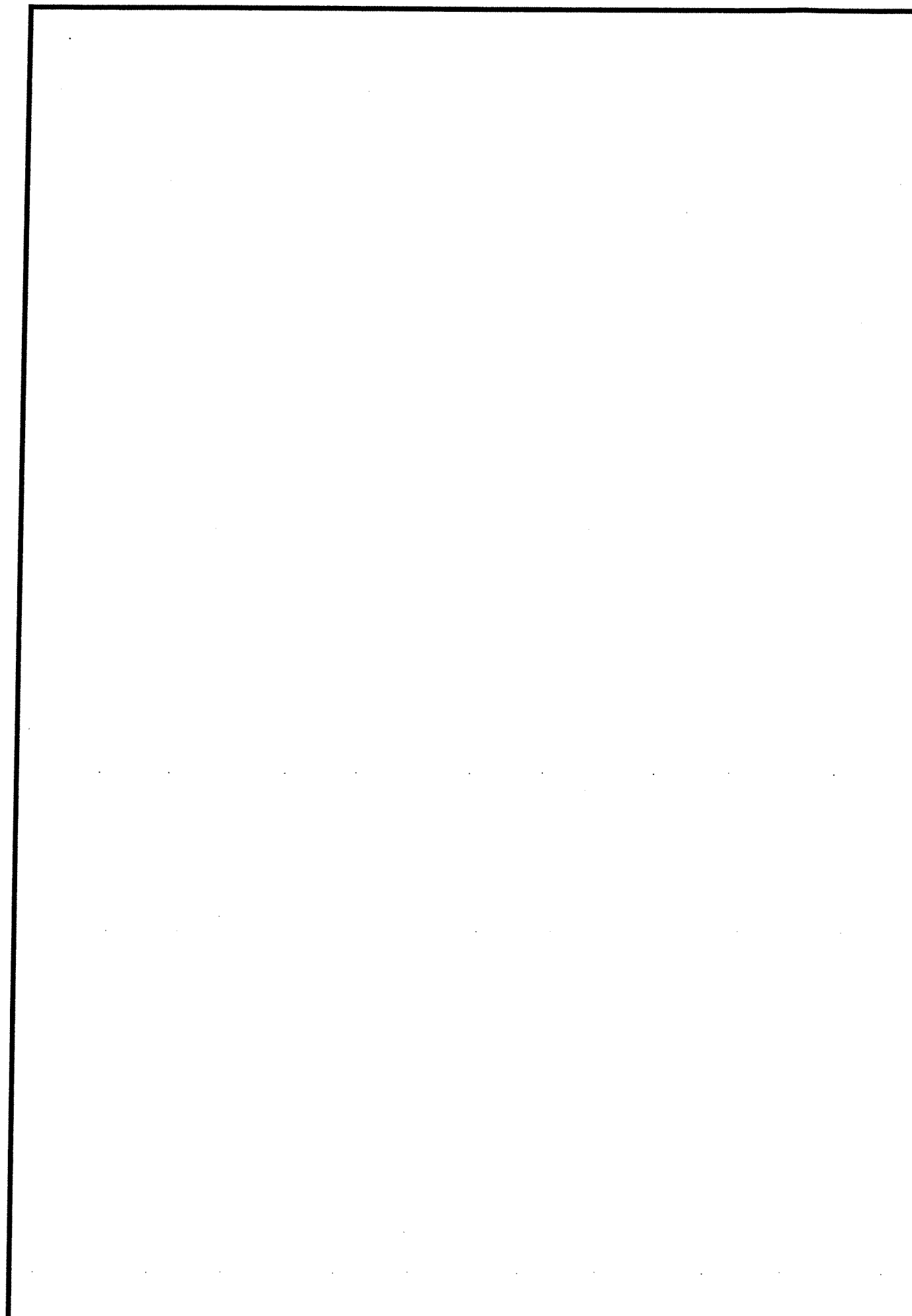

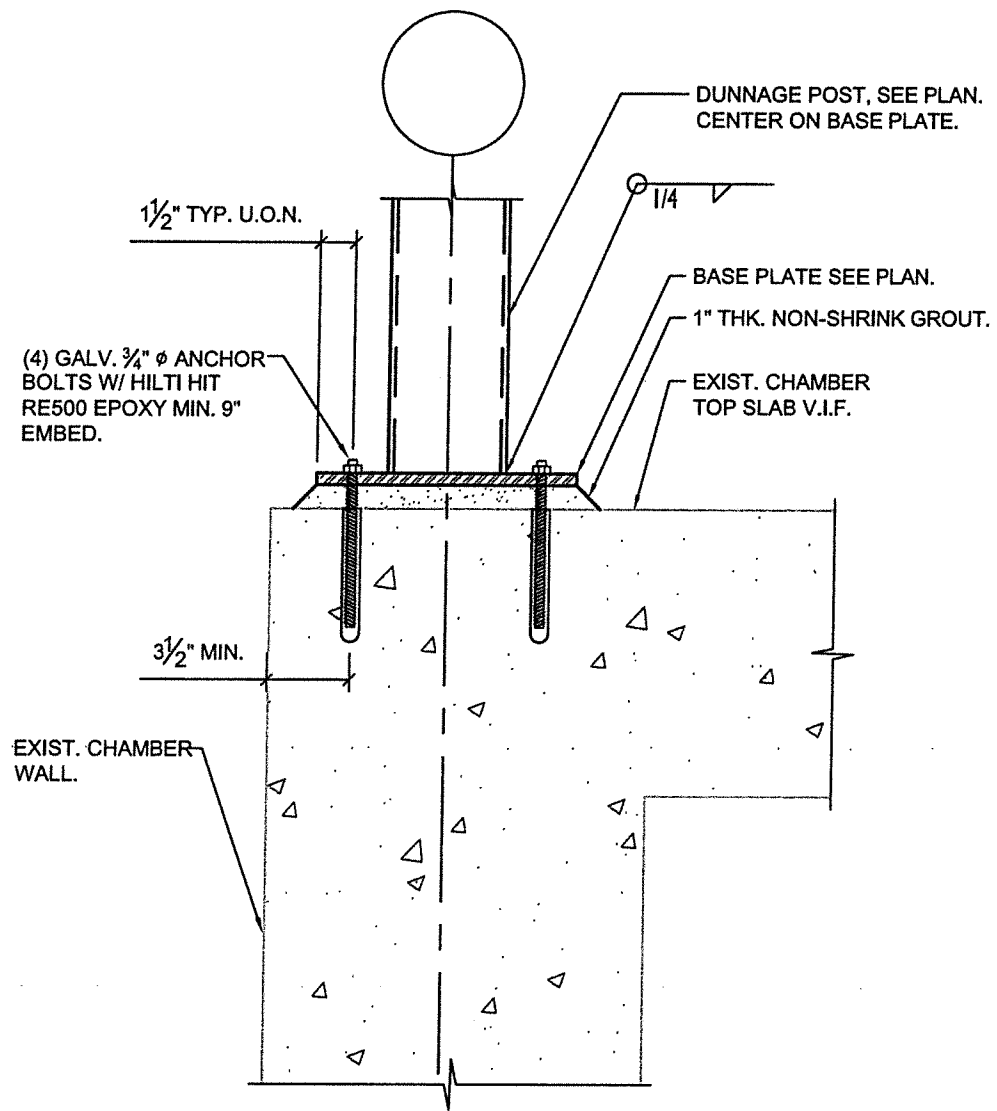

**1** TYP. DUNNAGE POST CONN.  
 SCALE: 1/2" = 1'-0"

- NOTES:**
1. ALL POSTS AND POST BASES TO BE CENTERED OVER CHAMBER WALL BELOW. FIELD VERIFY CHAMBER WALL EXTENTS. PRIOR TO FINAL PLACEMENT OF STEEL.

**2** TY  
 SCA

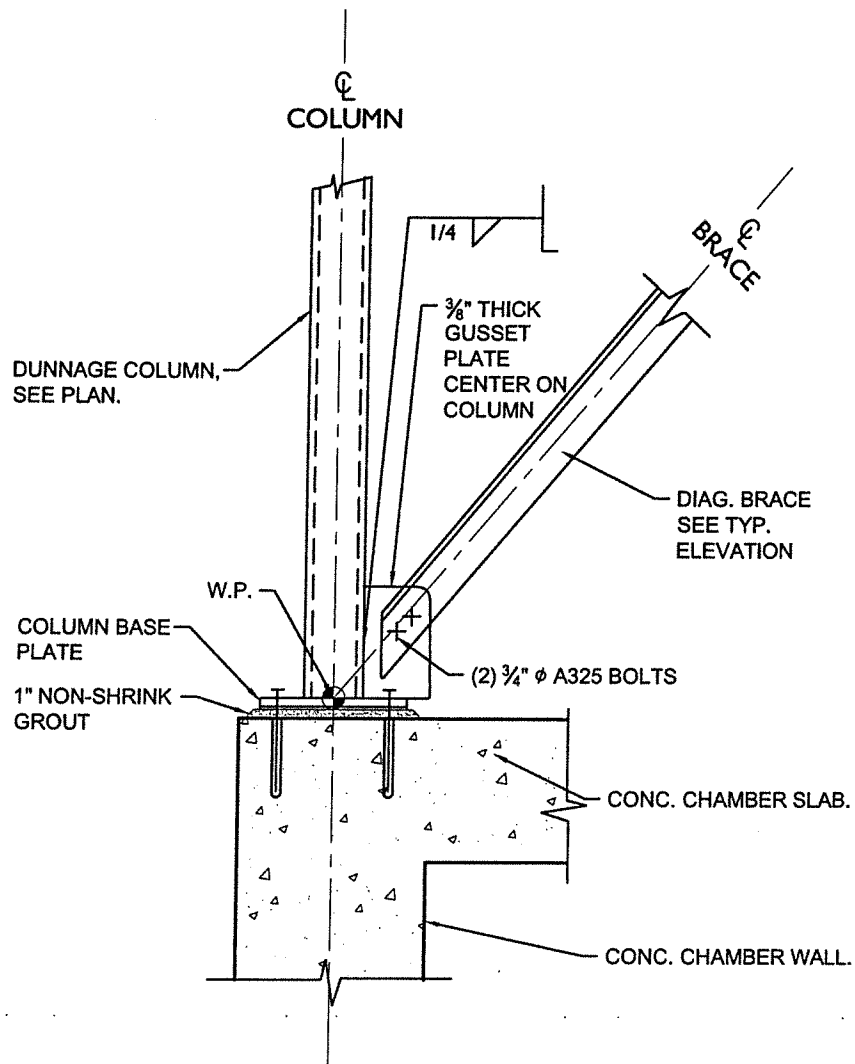

TYP. SHEAR 1 BEAMS TO CC 5/S-3.1.

(2) 3/4" φ A325 I

HSS 5x5 DUNN COLUMN SEE

**I** **TYP. BOTT. DETAIL AT BRACES**

SCALE: 3/4" = 1'-0"

**NOTES:**

1. SEE 1/S-3.1 FOR POST AND BASE PLATE CONNECTION TO CHAMBER.

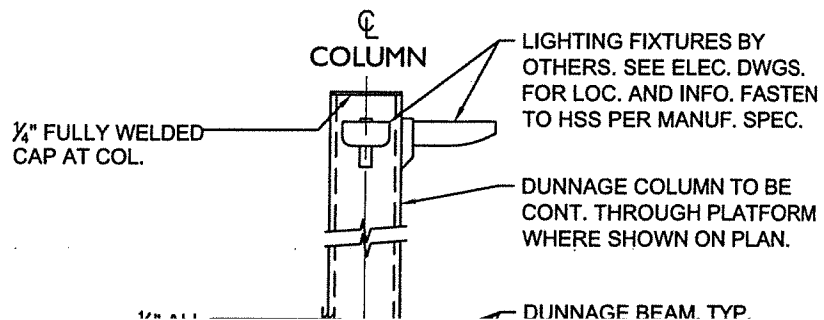

ADJUST WIDTH OF REMOVABLE PANELS TO PROVIDE CUSTOM FRAME OUT PANEL W/ 12"x12" REMOVABLE GRATING SECTION. TYP. (3) LOC. CUSTOM PANEL WITH REMOVABLE GRATING SECTION SHALL BE DESIGNED TO THE SAME LOAD REQUIREMENTS AS TYPICAL PANELS (SEE S-4.0). 12"x12" REMOVABLE GRATING SECTION TO BE CENTERED ABOVE PUMPS. SEE IMAGE FOR PROPOSED GRATING.

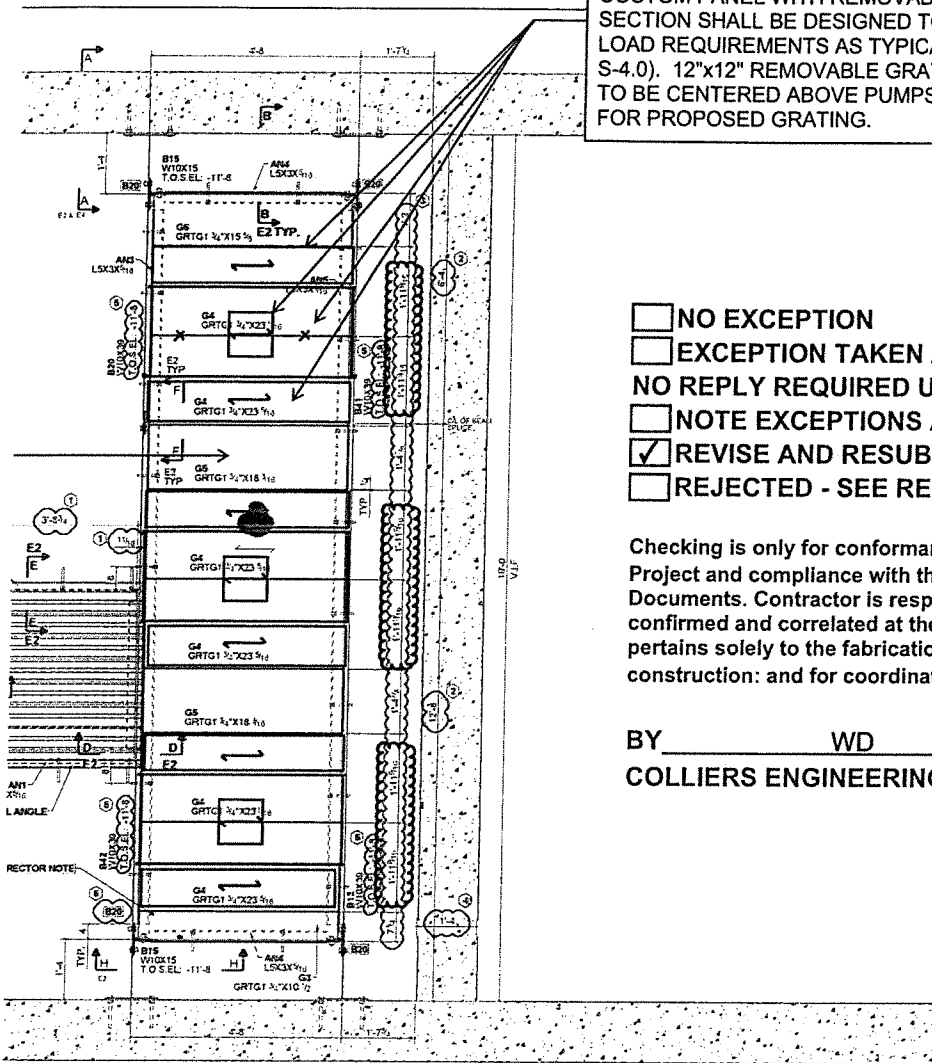
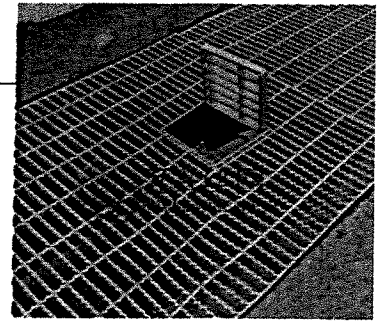

- NO EXCEPTION
- EXCEPTION TAKEN AS NOTED
- NO REPLY REQUIRED UNLESS CHECKED BELOW
- NOTE EXCEPTIONS AND CONFIRM IN WRITING
- REVISE AND RESUBMIT
- REJECTED - SEE REMARKS

Checking is only for conformance with the design concept of the Project and compliance with the information given in the Contract Documents. Contractor is responsible for dimensions to be confirmed and correlated at the job site; for information that pertains solely to the fabrication processes or to techniques to construction; and for coordination of the work of all trades.

BY WD DATE 1/16/2026  
**COLLIERS ENGINEERING & DESIGN**

ERECTOR NOTE:  
 TACK WELD PARTIAL WIDTH GRATING PANELS TO L543  
 AFTER LOOSE PANELS LOCATIONS ARE FINALIZED

**CHAMBER MID-LEVEL FRAMING PLAN**  
 (REF. DWG. NO.: AIS-1.0)

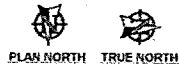

**ADDRESS OF THE JOB SITE:**  
 Long Branch, Monmouth County, NJ.

PROJECT  
**LONG BRANCH SEWERAGE AUTHORITY**

JOB NO.  
**1394-2025**

CLIENT NAME  
**RAPID PUMP**

DESCRIPTION  
**CHAMBER MID-LEVEL FRAMING PLAN**

Drawn By: SKA	Date: 08/20/2025	Scale:
Checked By: BLU	Date: 09/20/2025	
<b>IRON WORKS &amp; DESIGN, LLC</b>		
89 BROADWAY		
ELIZABETH, NJ 07206		
908-361-5367		
ironworksanddesign@gmail.com		

Sheet No.  
**E1**  
 Revision No:

LONG BRANCH SEWERAGE AUTHORITY  
150 JOLINE AVENUE  
P.O. BOX 720  
LONG BRANCH, NJ 07740

RECEIVED

FEB 4 2026

L.B. SEWERAGE AUTHORITY

FORM E-6 (Page 1 of 2)

APPLICATION FOR CHANGE OF USE OF EXISTING SEWERAGE FACILITIES

(UNIT CHANGES)

FILL IN AS EACH ITEM MAY APPLY - USE N/A IF NON-APPLICABLE

Date 02/05/26

Application for CHANGE OF USE OF SEWERAGE FACILITIES IN LONG BRANCH, COUNTY OF MONMOUTH, STATE OF NEW JERSEY. This application must be filed with the Executive Director of the Authority. Please answer all questions.

Application is hereby made for a change of use of existing sewerage facilities for a ruling on the system layout, characteristics, capacity, and requirements.

- Applicant's Name Jang Singh (532 Broadway (1c))  
Address ~~532 B~~ 10 Zechany way  
Eatontown NJ 07724 Phone (732) 939 3641  
Contact Person Name Jang Singh Phone (732) 939 3641
- Name of Present Property Owner Jang Singh  
Address 10 Zechany way Eatontown  
NJ- 07724 Phone (732) 939 3641
- Interest of applicant if other than owner of property \_\_\_\_\_
- Key Location or Street Location of Project 536 Broadway  
Long branch NJ 07740  
Block No. 176 Lot No. 37 Unit C

Tom, etc

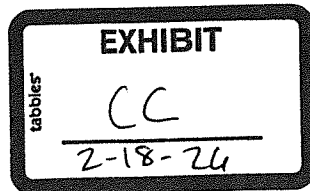

FORM E-6 (Page 2 of 2)

(UNIT CHANGES) 3 to 2 units

5. Describe: a) prior use Chinese Restaurant with  
b) new use Bath<sup>room</sup> removed & combined, Convenience store
6. Effective Date of Change of Use 02/04/26

7. Owner and applicant have read the LBSA Rules and Regulations and fully understand all necessary requirements. Yes

All sewer service charges must be paid up to date in order for the unit change to be effective.

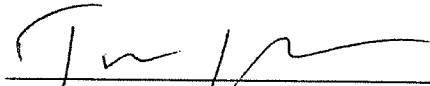
  
\_\_\_\_\_  
(Signature of Owner)

\_\_\_\_\_  
(Signature of Applicant)

Jang Singh  
\_\_\_\_\_  
(Name of Owner, typed/printed)

\_\_\_\_\_  
(Name of Applicant, typed/printed)

Member  
\_\_\_\_\_  
(Owner's Position or Title)

\_\_\_\_\_  
(Applicant's Position or Title)

8. Inspectors Report \_\_\_\_\_

## RISK MANAGEMENT CONSULTANT'S AGREEMENT

**THIS AGREEMENT** entered into this 18th day of February 2026, between the Long Branch Sewerage Authority (hereinafter referred to as GOVERNING BODY) and Brown & Brown Metro, LLC (hereinafter referred to as the CONSULTANT).

**WHEREAS**, the CONSULTANT has offered to the GOVERNING BODY professional risk management consulting services as required in the bylaws of the New Jersey Utility Authorities Joint Insurance Fund and;

**WHEREAS**, the GOVERNING BODY desires these professional services pursuant to the resolution adopted by the governing body of the GOVERNING BODY at a meeting held on February 18th, 2026 and;

**NOW, THEREFORE**, the parties in consideration of the mutual promises and covenants set forth herein, agree as follows:

- I. For and in consideration of the amount stated hereinafter, the CONSULTANT shall:
  - a) Assist the GOVERNING BODY in identifying its insurable Property & Casualty exposures and to recommend professional methods to reduce, assume or transfer the risk or loss.
  - b) Assist the GOVERNING BODY in understanding the various coverages available from the Monmouth County Municipal Joint Insurance Fund.
  - c) Review with the GOVERNING BODY any additional coverages that the CONSULTANT feels should be carried but are not available from the FUND and subject to the GOVERNING BODY's authorization, place such coverages outside the FUND.
  - d) Assist the GOVERNING BODY in the preparation of applications, statements of values, and similar documents requested by the FUND, it being understood that this Agreement does not include any appraisal work by the CONSULTANT.
  - e) Review Certificates of Insurance from contractors, vendors and professionals when requested by the GOVERNING BODY.
  - f) Review the GOVERNING BODY's assessment as prepared by the FUND and assist the GOVERNING BODY in the preparation of its annual insurance budget.
  - g) Review the loss and engineering reports and generally assist the safety committee in its loss containment objectives. Also, attend no less than one (1) municipal safety committee meeting per annum to promote the safety objectives and goals of the GOVERNING BODY and the FUND.

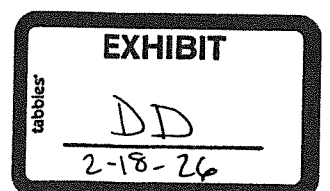

- h) Assist where needed in the settlement of claims, with the understanding that the scope of the CONSULTANT's involvement does not include the work normally done by a public adjuster.
  - i) Perform any other risk management related services required by the FUND's bylaws.
- 2. In exchange for the above services, the CONSULTANT shall be compensated in the following manner:
  - a) The GOVERNING BODY authorizes the FUND to pay its CONSULTANT compensation for services rendered, an amount equal to six percent (6.0%) of the GOVERNING BODY's annual assessment as promulgated by the FUNDS. Said fee shall be paid to the CONSULTANT within thirty (30) days of payment of the GOVERNING BODY's assessment.
  - b) For any insurance coverages authorized by the GOVERNING BODY to be placed outside the FUND, the CONSULTANT shall receive as compensation the normal brokerage commissions paid by the insurance company. The premiums for said policies shall not be added to the FUND's assessment in computing the fee outlined in 2 (a).
- 3. The term of this Agreement shall be one (1) year. However, this Agreement may be terminated by either party at any time by mailing to the other written notice, certified mail return receipt, calling for termination at not less than thirty (30) days thereafter. In the event of termination of this Agreement, the CONSULTANT's fees outlined in 2 (a) above shall be prorated to date of termination.

*ATTEST:*

*GOVERNING BODY:*

---

---

*ATTEST:*

*CONSULTANT:*

---

---